

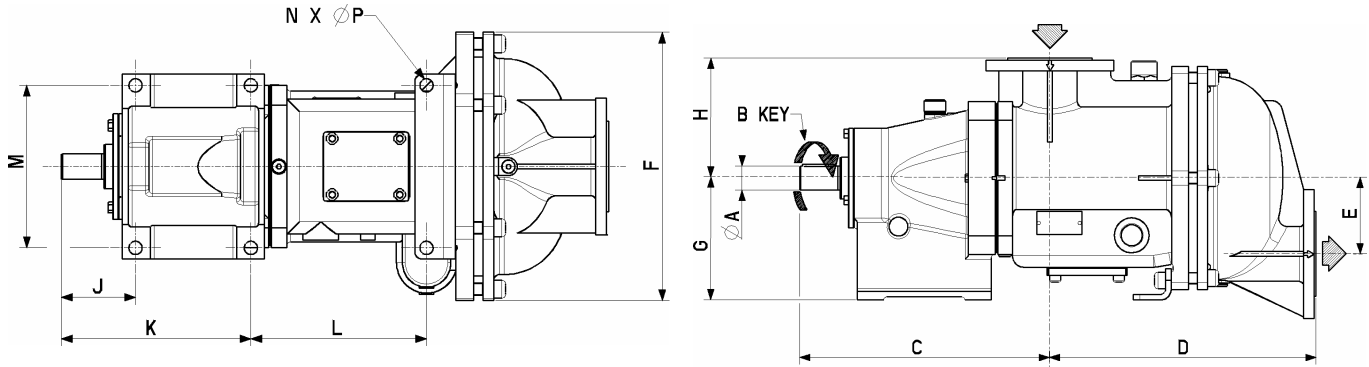

DIMENSIONS
Models: C12-A, C18-A
Ductile Iron Pumps
Unit Style PO

Page Number	1001-105
Effective	March 2004
Replaces	Feb 2001
Section	1001



C12-A & C18-A PUMP DIMENSIONS

		ϕA	B	C	D	E	ϕF	G	H	J	K	L	M	N (qty)	ϕP
Ductile Iron	in	-	-	14 7/32	15 1/8	4 19/64	14 19/64	6 57/64	6 25/32	3 31/32	10 5/32	9 13/32	8 21/32	-	45/64
	mm	35	10	361	384	109	363	175	172	101	258	239	220	6	18

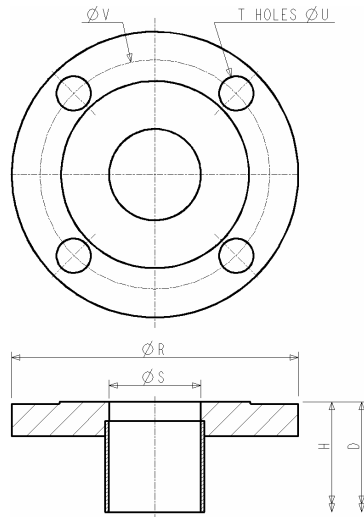

C12-A & C18-A 2 1/2" FLANGE DIMENSIONS

DIMENSIONS	R		S		T	ϕU		ϕV	
	in	mm	in	mm	Quantity	in	mm	in	mm
ANSI Comp.	7 1/4	185	2 1/2	65	4	45/64	18	5 1/2	140