

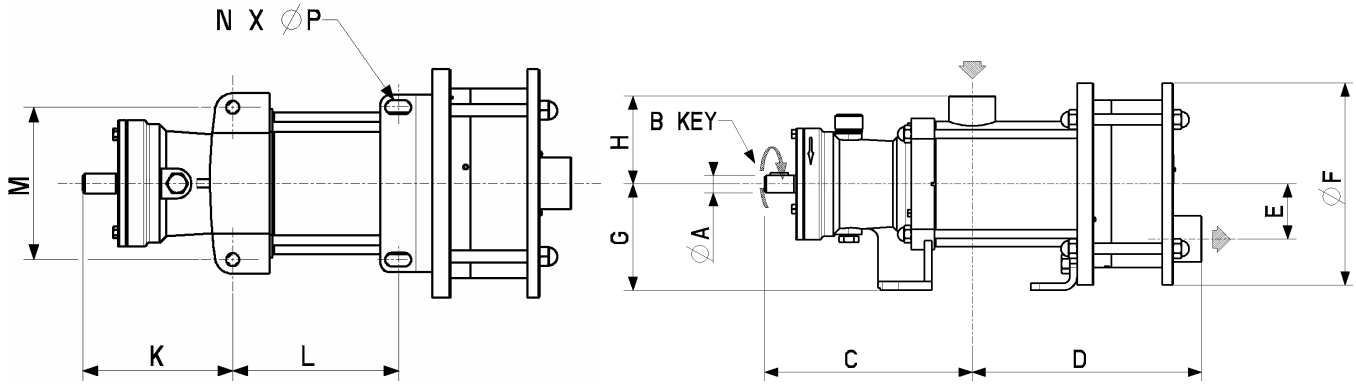

DIMENSIONS
Models: C1-I, C2-I
Stainless Steel Pumps
Unit Style PO

Page Number	1001-100
Effective	March 2004
Replaces	June 2003
Section	1001



C1-I & C2-I STAINLESS STEEL PUMP DIMENSIONS

	φA	B	C	D	E	φF	G	H	K	L	M	N (qty)	φP
in	-	-	6 9/16	See Below	2 3/32	7 23/32	4 1/8	See Below	3 3/4	5 3/16	3 3/8	-	25/64
mm	19	6	167	See Below	53	196	105	See Below	95.5	131.5	86	4	10

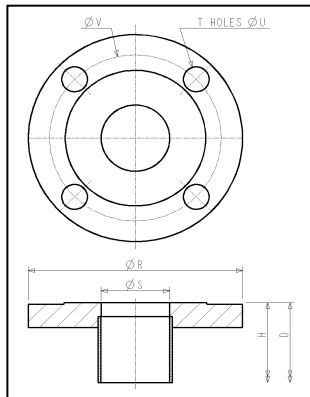

ANSI

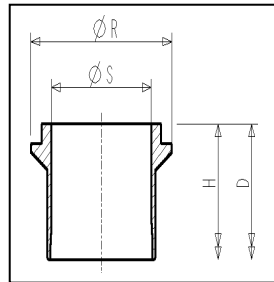

CHERRY BURREL

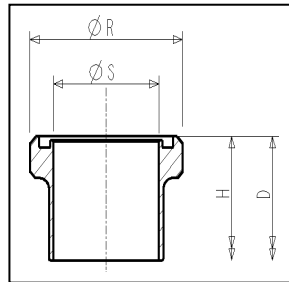

SMS

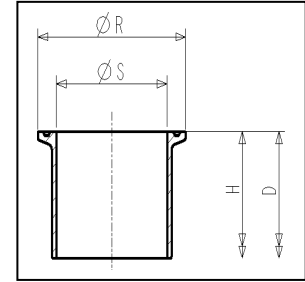

CLAMP

C1-I & C2-I 1 1/2" FLANGE DIMENSIONS

	R		S		H		D (C1-I)		D (C2-I)		T Quantity	φU		φV	
	in	mm	in	mm	in	mm	in	mm	in	Mm		in	mm	in	mm
ANSI Compatible	4 59/64	125	1 3/8	35	4 9/64	105	9 1/32	229.5	9 9/32	236	4	5/8	15.8	3 7/8	98.4
Cherry Burrel	1 63/64	50.5	1 3/8	35	3 23/64	90	8 7/16	214.5	8 11/16	221					
SMS	2 11/32	59.5	1 3/8	35	3 23/64	90	8 7/16	214.5	8 11/16	221					
Clamp	1 63/64	50.5	1 3/8	35	3 23/64	90	8 7/16	214.5	8 11/16	221					