

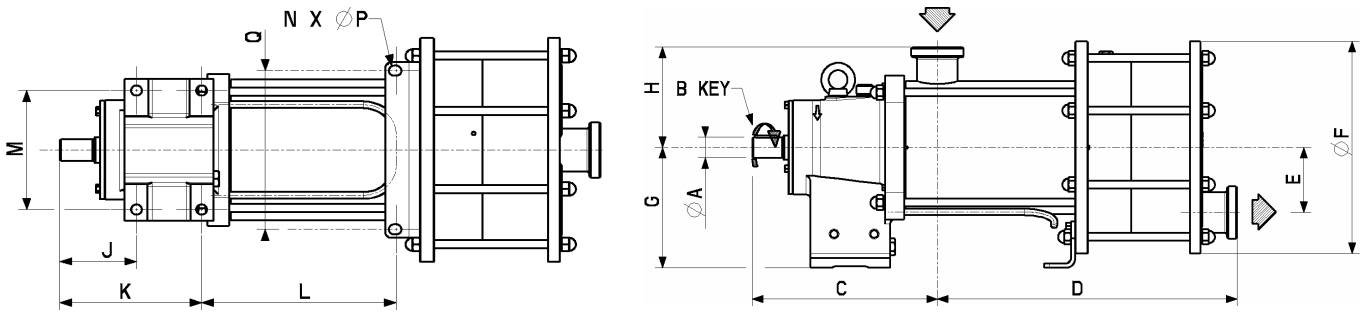

DIMENSIONS
Models: C24-I, C36-I
Stainless Steel Pumps
Unit Style PO

Page Number	1001-103
Effective	March 2004
Replaces	Oct 2001
Section	1001



C24-I & C36-I STAINLESS STEEL PUMP DIMENSIONS

	ϕA	B	C	D	E	ϕF	G	H	J	K	L	M	N (qty)	ϕP	QP
in	-	-	13 19/32	See Below	4 3/4	15 9/16	8 13/16	See Below	5 1/16	9 11/32	12 13/16	8 9/32	-	45/34	11 1/32
mm	38	10	345.5	See Below	121	395	224	See Below	128.5	237.5	325.5	210	6	18	280

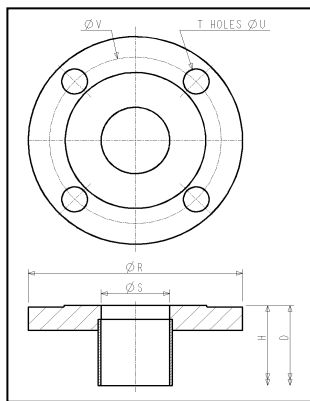

ANSI

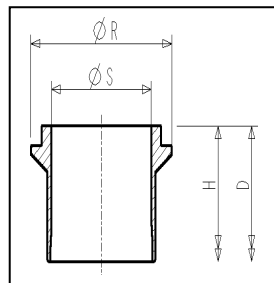

CHERRY BURREL

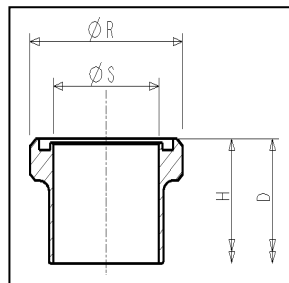

SMS

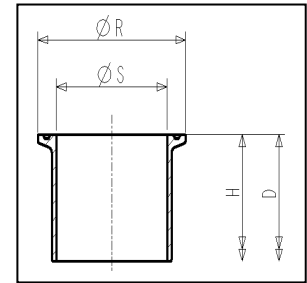

CLAMP

C24-I & C36-I 3" FLANGE DIMENSIONS

	R		S		H		D (C24-I)		D (C36-I)		T	ϕU		ϕV	
	in	mm	in	mm	in	mm	in	mm	in	mm		Quantity	in	mm	in
ANSI Compatible	7 15/32	190	2 27/32	72.1	7 23/64	187	21	533.5	22 1/8	560	4	3/4	19	6	152.4
Cherry Burrel	3 7/8	98.4	2 27/32	72.1	7 23/64	187	21	533.5	22 1/8	560					
SMS	3 27/32	98	2 27/32	72.1	7 23/64	187	21	533.5	22 1/8	560					
Clamp	3 19/32	91	2 27/32	72.1	7 23/64	187	21	533.5	22 1/8	560					