

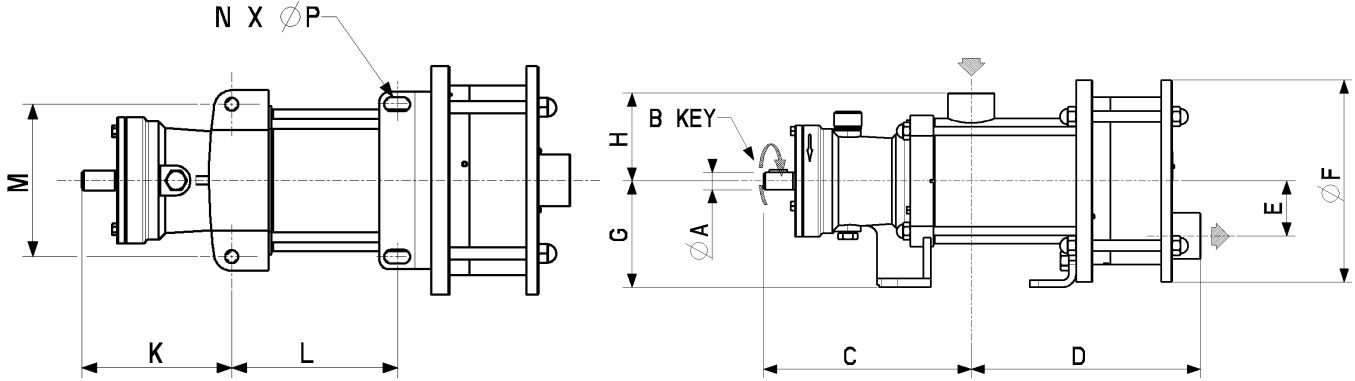

DIMENSIONS
Models: C4-I, C8-I
Stainless Steel Pumps
Unit Style P0

Page Number	1001-101
Effective	March 2004
Replaces	Oct 2001
Section	1001



C4-I & C8-I STAINLESS STEEL PUMP DIMENSIONS

	ϕA	B	C	D	E	ϕF	G	H	K	L	M	N (qty)	ϕP
in	-	-	9 5/32	See Below	2 7/16	8 31/32	4 23/32	See Below	5 29/32	6 25/32	5 63/64	-	35/64
mm	20	6	232.5	See Below	62	228	120	See Below	150	172	152	4	14

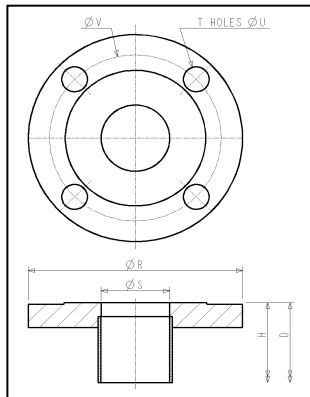

ANSI

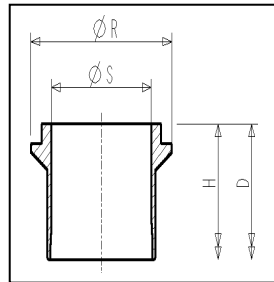

CHERRY BURREL

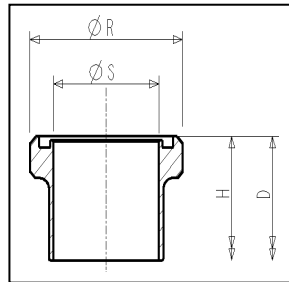

SMS

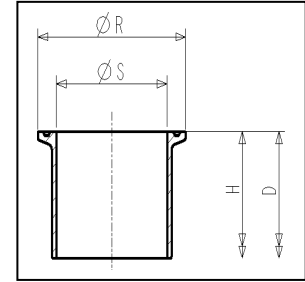

CLAMP

C4-I & C8-I 2" FLANGE DIMENSIONS

	R		S		H		D (C4-I)		D (C8-I)		T Quantity	ϕU		ϕV	
	in	mm	in	mm	in	mm	in	mm	in	mm		in	mm	in	mm
ANSI Compatible	5 29/32	150	1 57/64	48	4 19/64	109	10 33/64	267	11 3/16	284	4	45/64	18	4 3/4	120.5
Cherry Burrel	2 41/64	67	1 7/8	47.5	4 19/64	109	10 33/64	267	11 3/16	284					
SMS	3 21/64	84.5	1 57/64	48	4 19/64	109	10 33/64	267	11 3/16	284					
Clamp	2 27/32	64	1 57/64	48	4 19/64	109	10 33/64	267	11 3/16	284					