

# BLACKMER PARTS LIST

## PUMP MODEL: NP1.5B

961202      **PARTS LIST**  
Page 1 of 2      **103-A01**

Section    103  
Effective    Sept 2007  
Replaces    Dec 2005

See Instructions 103-A00 for Installation, Operation and Maintenance

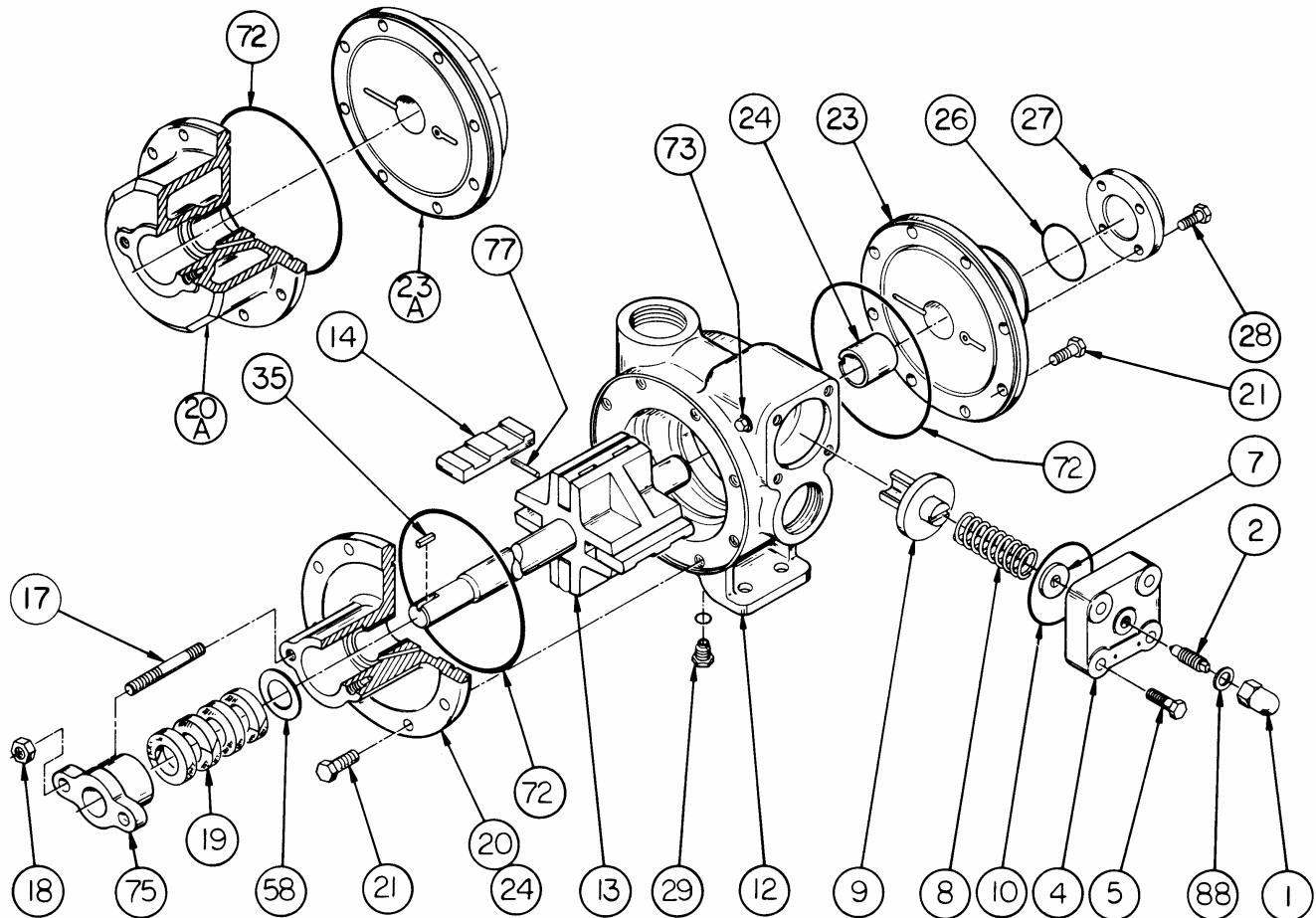

Ref. No.	Description	Parts per Pump	Part No.	Ref. No.	Description	Parts per Pump	Part No.
1	Cap - Relief Valve (R/V)	1	411452	20	Head & Bushing Asy. - Inboard	1	031252
2	Adjusting Screw - R/V	1	431401	20A	Jacketed Head & Bushing Asy. - Inbd. <sup>3</sup>	0 - 1	031256
4	Cover - R/V (Std.)	1	411469	21	Capscrews - Head	16	920331
	Cover - R/V <sup>1</sup>		411268	23	Head & Bushing Asy. - Outboard	1	031253
5	Capscrew - R/V Cover (Std.)	4	920316	23A	Jacketed Head & Bushing Asy. - Outbd.	0 - 1	031257
	Capscrew - R/V Cover <sup>1</sup>		920369	24	Sleeve Bearing	2	<sup>4</sup> 161200
7	Spring Guide - R/V	1	423955	26	O-Ring - Bearing Cover (FKM) (Std.)	1	<sup>4</sup> 702205
8	Spring - R/V (51-75 psi)	1	471420		O-Ring - Bearing Cover (PTFE)		702076
	Spring - R/V (76-100 psi)		471425	27	Bearing Cover	1	041215
	Spring - R/V (101-150 psi)		471424	28	Capscrews - Bearing Cover	4	920178
	SS Spring - R/V (151-200 psi) <sup>1</sup>		471268	29	Pipe Plug Asy. <sup>2</sup> (SAE # 6) (FKM) (Std)	1	908212
9	Valve - R/V (Std.)	1	451416	Pipe Plug Asy. <sup>2</sup> (SAE # 6) (PTFE)		908213	
	Valve - R/V (Nickel Plated)		451414	35	Key - Shaft	1	<sup>4</sup> 909160
10	O-Ring - R/V Cover (FKM) (Std.)	1	<sup>4</sup> 702212	72	O-Ring - Head (FKM) (Std.)	2	<sup>4</sup> 702048
	O-Ring - R/V Cover (PTFE)		702213		O-Ring - Head (PTFE)		702111
12	Cylinder (Std.)	1	021203	73	Gage Plug	2	908198
	Cylinder w/ Drain (Cast Iron) <sup>2</sup>		021202	77	Push Rods	2	<sup>4</sup> 123305
13	Rotor & Shaft (Std.)	1	261201	88	Gasket - R/V Cap	1	<sup>4</sup> 701981
14	Vane - Duravane (Std.)	4	<sup>4</sup> 091219	—	Kit — Maintenance	—	898928
	Vane - EC Cast Iron		093327				
	Vane - EC Bronze		093328				

SS = Stainless Steel    EC = Extra Clearance

<sup>1</sup>Optional High Pressure Relief Valve – parts must be used as a group (includes p/n's 411268, 920369, and 471268).

<sup>2</sup>SAE Plug standard with pump cylinder p/n 021202.

<sup>3</sup>Crane #9 option not available with jacketed heads.

<sup>4</sup>Included in Maintenance Kit

Keep this parts list with Installation, Operation and Maintenance Instructions.

**PACKING - STANDARD**

Ref. No.	Part Name	Parts Per Pump	Part No.
17	Stud - Packing Follower	2	921450
18	Nut - Packing Follower Stud	2	922428
19	Packing Set	1	323376
58	Pack Washer	1	353307
75	Packing Follower	1	141205

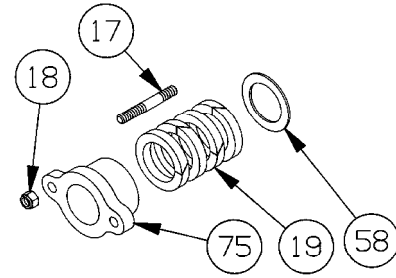

**LIP SEAL - OPTIONAL**

Ref. No.	Part Name	Parts Per Pump	Part No.
16	Capscrew - Follower	2	920316
75	Seal Follower	1	141205
152	Lip Seal Assembly (To 500°F)	1	702243
152D	Wave Spring	1	321201

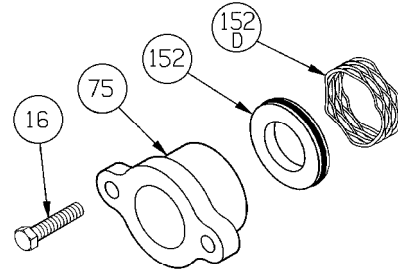

**COMMERCIAL MECHANICAL SEAL - OPTIONAL\***

Ref. No.	Part Name	Parts Per Pump	Part No.
16	Capscrew - Seal Retainer	2	920316
126	Seal Retainer	1	141206
153	Mechanical Seal Asy. Crane #9	1	331276

\*Not available for jacketed configuration.  
NOTE: Seal Materials (Ni-resist, Carbon, FKM)

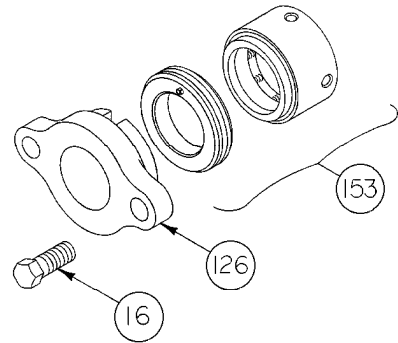

**TRIPLE-LIP CARTRIDGE SEAL - OPTIONAL**

Ref. No.	Part Name	Seal	Seal Rebuild Kit
—	<b>TRIPLE-LIP CARTRIDGE SEAL</b>	<b>331214</b>	<b>899102</b>
220	Shaft Sleeve O-Ring	2	X
221	Shaft Sleeve	1	
222	Gasket	1	X
223	Gland Plate Assembly	1	
224	Element O-Ring	1	X
225	Seal Spacer	1	X
226	Seal Element	3	X
227	Flushing Spacer	1	X
228	Flushing Spacer O-Ring	1	X
229	Retaining Ring	1	
230	Snap Ring	1	X
231	Shaft Sleeve Setscrews	6	X
233	Gland Capscrew	4	X
234	Flat Washer	4	X

X = Included in Seal Rebuild Kit

