



ANSI FLANGE

(ANSI 150 CLASS COMPATIBLE)

DIMENSIONS 103-115

Section	100
Effective	November 2001
Replaces	February 1993
Page	1/2

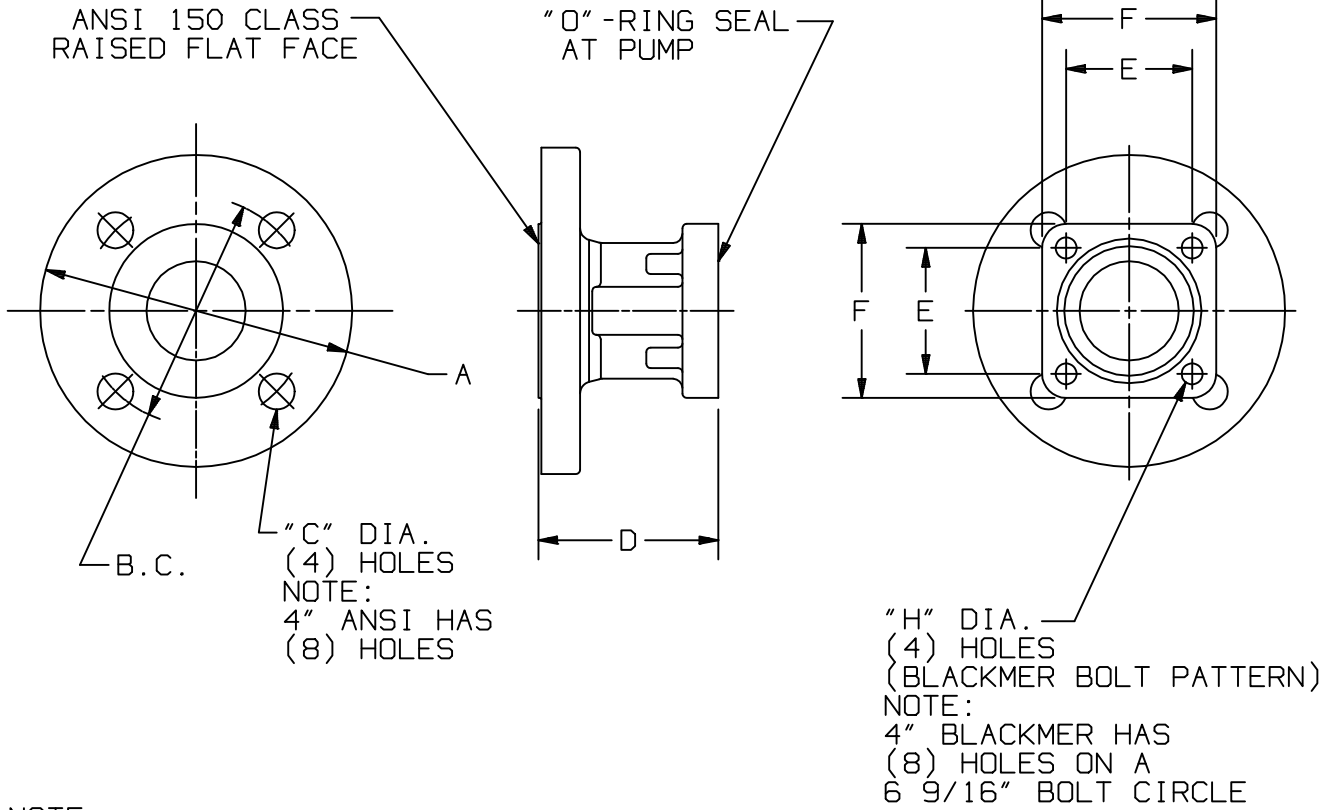

NOTE:
FLANGES SHOWN ARE DESIGNED TO FIT
BLACKMER "GX", "X" & "NP" PUMP MODELS

STANDARD MATERIAL
DUCTILE IRON: ASTM A536, 18%

FLANGE SIZE		DIMENSIONS							
		A	B.C.	C	D	E	F	H	
BLACKMER 2" TO ANSI 2" 150 Lb	IN	6 1/2	4 3/4	3/4	3 3/4	2 5/8	3 5/8	7/16	
	MM	165,1	120,6	19	95,2	66,7	95,2	11,1	
BLACKMER 2 1/2" TO ANSI 3" 150 Lb	IN	7 7/8	6	3/4	5	2 7/8	4	9/16	
	MM	200	152,4	19	127	73	101,6	14,3	
BLACKMER 3" TO ANSI 3" 150 Lb	IN	7 7/8	6	3/4	5	3 17/32	4 3/4	5/8	
	MM	200	152,4	19	127	89,7	120,6	15,9	
BLACKMER 4" TO ANSI 4" 150 Lb	IN	9	7 1/2	3/4	5	6 9/16	7 11/16	9/16	
	MM	220	190,5	19	127	166,7	195,2	14,3	
BLACKMER 4" BOLT PATTERN				(8) HOLES		BOLT CIRCLE	FLANGE DIA.	(8) HOLES	