

# BLACKMER PARTS LIST

With Installation and Maintenance Instructions  
**Motor Coupling Adapter Model: MCA280TC**

964530      **PARTS LIST**  
 Page 1 of 6      **108-F00**

Section | 108  
 Effective | Nov 2006  
 Replaces | Mar 2003

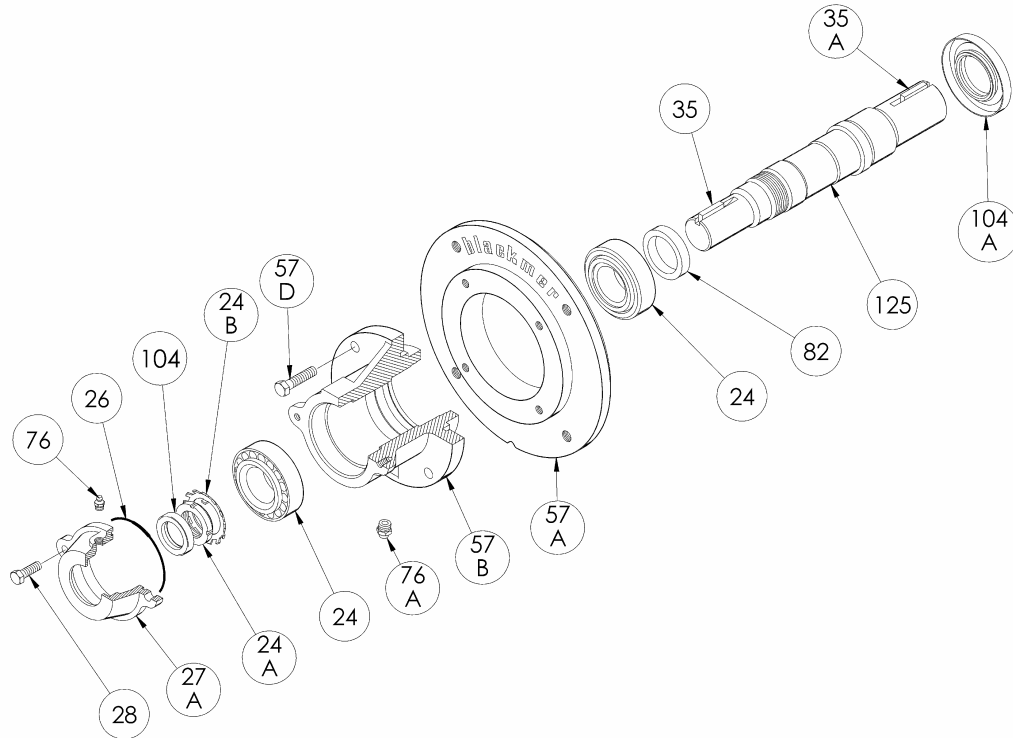

Ref. No.	Description	Parts per Unit	Part No.
24	Roller Bearing	2	903134
24A	Locknut - Bearing	1	903543
24B	Lockwasher - Bearing	1	903544
26	O-Ring - Bearing Cover	1	701936
27A	Bearing Cover	1	044502
28	Capscrews - Bearing Cover	4	920203
35	Shaft Key (3/8 x 1 5/8") - Motor	1	909163
35A	Shaft Key (1/2 x 2") - Outer Magnet	1	909191
57A	Housing - Motor Coupling Adapter	1	684550
57B	Bearing Housing - Motor Coupling Adapter	1	684551
57D	Capscrew - Bearing Housing	4	920369
76	Grease Fitting	1	317815
76A	Grease Relief Fitting	1	701992
82	Spacer	1	374500
104	Grease Seal	1	331907
104A	Grease Seal	1	701201
125	Shaft - Motor Coupling Adapter	1	704500

NOTE: Motor Coupling Adapter mounting hardware is included with pump assembly. See the appropriate Parts Lists and Installation, Operation and Maintenance manual for the Pump Model you are servicing. (Table Page 3)

## Magnet Assembly Selection Table

Pump Model	Motor Frame	Magnetic Coupling Size	Torque lbs ft (Nm)
SMVP200B	284TC - 286TC	MC80	80 (108.4)
SMVP300B		MC130	130 (176.2)

# SAFETY DATA



**This is a SAFETY ALERT SYMBOL.**

When you see this symbol on the product, or in the manual, look for one of the following signal words and be alert to the potential for personal injury, death or major property damage



**Warns of hazards that WILL cause serious personal injury, death or major property damage.**



**Warns of hazards that CAN cause serious personal injury, death or major property damage.**



**Warns of hazards that CAN cause personal injury or property damage.**

**NOTICE:**

Indicates special instructions which are very important and must be followed.

**NOTICE:**

Blackmer Seal-Less pumps **MUST** only be installed in systems, which have been designed by qualified engineering personnel. The system **MUST** conform to all applicable local and national regulations and safety standards.



This manual is intended to assist in the installation and maintenance of the Blackmer Motor Coupling Adapter, and **MUST** be kept with the pump.

Blackmer Seal-Less pump service shall be performed by qualified technicians **ONLY**. Service shall conform to all applicable local and national regulations and safety standards.

Thoroughly review the pump manual, all instructions and hazard warnings, **BEFORE** performing any work on the Blackmer Seal-Less pumps.

Maintain **ALL** system and Blackmer Seal-Less pump operation and hazard warning decals.

**WARNING**

Strong magnetic field

**WARNING**



Explosive atmosphere can cause serious injury

**Strong magnetic field can cause personal injury or death to individuals with medical implants or other magnetic field sensitive medical conditions**

**Rare earth magnets may create sparks through contact and handling. Never handle rare earth magnets in explosive atmospheres where sparking may ignite that atmosphere**

**CAUTION**



Strong magnetic field can cause personal injury

**Failure to use care when handling magnets can cause personal injury**

**WARNING**



Hazardous or toxic fluids can cause serious injury.

**If pumping hazardous fluids, system must be flushed, prior to performing service or maintenance**

**WARNING**



Hazardous voltage. Can shock, burn or cause death.

**Failure to disconnect and lockout electrical power before attempting maintenance can cause shock, burns or death**

**WARNING**



Hazardous machinery can cause serious personal injury

**Failure to disconnect and lockout electrical power or engine drive before attempting maintenance can cause serious personal injury or death**

**WARNING**



Hazardous pressure can cause serious personal injury or property damage

**Failure to relieve system pressure prior to performing pump service or maintenance can cause personal injury or property damage.**

**WARNING**



Hazardous pressure can cause personal injury or property damage

**Disconnecting fluid or pressure containment components during pump operation can cause serious personal injury, death or major property damage**

**WARNING**



Do not operate without guards in place

**Operation without coupling guard can cause serious personal injury, death or major property damage**

# INSTALLATION

## NOTICE:

Installation and maintenance shall be performed by qualified technicians only, following the appropriate procedures and warnings as presented in this manual.

## NOTICE:

Clear work area of all tools and materials affected by magnets. Non-magnetic work surface recommended.

## NOTICE:

The following instructions include only the steps necessary to install and perform maintenance on the Blackmer motor coupling adapter. Before proceeding, read and follow all pump instructions and hazard warnings provided in the "Installation, Operation and Maintenance" manual listed below.

PUMP MODEL	PUMP INSTRUCTION MANUAL	PUMP PARTS LIST
SMVP200B, SMVP300B	108-B00	108-B03



## NOTICE:

Following all hazard warnings and instructions provided in the "Safety Data" section of this manual.

## MOTOR COUPLING ADAPTER INSTALLATION

### NOTICE:

The magnet housing and pump must be properly mounted prior to installing the motor coupling adapter assembly. Refer to "pump mounting" in the appropriate Blackmer pump instruction manual.

<b>⚠ WARNING</b>

Strong magnetic field
<b>⚠ CAUTION</b>

Strong magnetic field can cause personal injury

Strong magnetic field can cause personal injury or death to individuals with medical implants or other magnetic field sensitive medical conditions

Failure to use care when handling magnets can cause personal injury

- Put drive key in keyway on motor coupling adapter shaft.
- Loosely assemble bushing with bolts & outer magnet. Slide magnet assembly onto motor coupling adapter shaft.
- Position bushing and magnet to Reference Dim "B", (see Table 1) and tighten setscrew over drive key. Tighten the 3 bolts in a uniform sequence, torque to 15 ft lbs. (20.3 Nm)
- When bolts are tightened, take a measurement for Dim "A". (see table 1)

- If Measurement "A" does not match the value in the Table, the bushing **MUST** be repositioned with a new Dim "B". Loosen the bolts and setscrew.

### If Measurement "A" is High:

Move the bushing towards the motor "C-Face"  
New Dim "B" = Dim "B" from the Table less the difference between Measurement "A" and Dim "A" from the Table

### If Measurement "A" is Low:

Move the bushing away from the motor "C-Face"  
New Dim "B" = Dim "B" from the Table plus the difference between Measurement "A" and Dim "A" from the Table

- Retighten setscrew over drive key. Repeat Step 4 — Step 6
- When Dim "A" is set correctly.** Ensure that Shaft & Outer Magnet assembly rotate freely without binding
- Slide the motor adapter ring (86) over the outer magnet to the "Face" of the motor coupling adapter. Ensure that the flange of the motor adapter ring is fully and squarely seated. Install the adapter ring capscrews (56) torquing to 40 lbs ft (54 Nm) Starting from the pump side of the magnet housing (57), thread the two jackscrews (54C) into the jackscrew holes in the housing until they extend through approximately 2 inches.

## NOTICE:

Be prepared for strong magnet attraction between the inner and outer magnets, forcibly pulling the motor coupling adapter assembly inward.

- Ensure that the magnet housing (57) is bolted to the base.
- Using an appropriately sized hoist, CAREFULLY insert the outer magnet and motor into the mounted magnet housing (57).
- Gradually unscrew the jackscrews to allow the motor to fully engage in the housing.
- With the magnet housing fully and squarely seated, install the four housing capscrews (54B), torquing to 40 lbs ft (54 Nm)

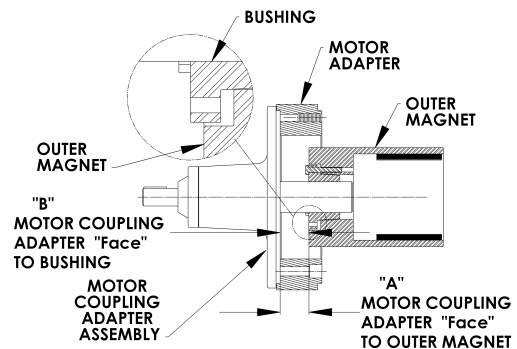

Figure 1

SET DIMENSIONS FOR MAGNETS	
SMVP200B, 300B	
MC130	
DIM "A" MAGNET SET	DIM "B" BUSHING REF
1.747 in (44.4 mm)	1.737 in (44.1 mm)

Table 1 – Magnet Set Dimensions

# MAINTENANCE

## NOTICE:

Follow all hazard warnings and instructions provided in the "safety data" section of this manual.

## LUBRICATION

The motor coupling adapter bearings should be lubricated every one to eight weeks, depending on the operating duty and the system conditions.

### Recommended Grease:

Exxon<sup>®</sup>, Ronnex MP Grease;  
Mobil<sup>®</sup>, MOBILITH AW-2 (64353-6) Grease or equivalent Lithium Grease.

### Lubrication Procedure:

1. Remove the grease relief fitting (76A) from the motor coupling adapter housing (57A).
2. Using a grease hand gun, apply grease into the grease fitting (76) until grease begins to escape from the grease relief fitting port.
3. Re-install the grease relief fitting (76A).

## MOTOR COUPLING ADAPTER DISASSEMBLY

1. Disengage the coupling between the coupling adapter and the motor or gear reducer.

## NOTICE:

Be prepared for strong magnet attraction between the inner and outer magnets, forcibly pulling the motor coupling adapter assembly inward.

2. Remove the capscrews (54B) connecting the pump magnet housing to the motor adapter. Attach an appropriately sized hoist to the motor coupling adapter to prevent it from dropping when the magnets release. Thread the two jackscrews (54C), located in the pump magnet housing (57), inward (clockwise) to force the motor coupling adapter away from the housing, releasing the magnets.
3. Hoist the motor coupling adapter and outer magnet assembly away from the magnet housing.
4. Remove the motor adapter capscrews (56), and the motor adapter (86) from the motor coupling adapter assembly.
5. Place a flat wrench or "plate" between the three bushing capscrews and the "face" of the motor coupling adapter. Loosen the three Capscrews located in the bushing (87) allowing them to bottom out against the flat wrench or "plate" and assist in removing the outer magnet. If room allows for the screws to be removed completely, the bushing is predrilled with jacking holes for the purpose of removing the outer magnet from the bushing.
6. When outer magnet has been removed from the bushing, loosen setscrew and remove bushing and keyway from the motor shaft.

7. Remove the two bearing cover capscrews (28) and slide the bearing cover (27A) and O-ring (26) off the adapter shaft. Discard the bearing cover O-ring. Remove the grease seal (104) from the bearing cover and discard.
8. Bend up the lockwasher tang (24B) engaged in the locknut and turn the locknut (24A) using a Blackmer locknut tool, or spanner wrench; counterclockwise to remove it from the shaft. Remove the lockwasher from the shaft.
9. From the opposite side of the coupling adapter assembly, pull the adapter shaft (125) through the housing and out of the flanged end.
10. Remove the grease seal (104A) from the motor coupling adapter-housing (57A) with a seal removal tool. Discard the grease seal.
11. Pull the spacer (82) and the two bearing cones (24) from the housing assembly.
12. The bearing cups are press fit into the housing and require an arbor press or a bearing removal tool to be removed. Notches in the housing, which expose a portion on either side of each bearing, can be used to facilitate removal.

## MOTOR COUPLING ADAPTER ASSEMBLY

Before reassembling the motor coupling adapter, clean each part thoroughly. Wash out the bearing area in the housing to remove any old grease.

1. Bearing cups must be installed prior to reassembly. When replacing the bearing, the entire two-piece bearing assembly, including the bearing cup and bearing cone, must be replaced, See Figure 2 for reference.
  - a. Grease the outer edges of the bearing cups.
  - b. With the beveled edge inward, arbor press a bearing cup into the bearing recess on the inboard end (driven end) of the adapter housing.
  - c. Press the other bearing cup, beveled edge inward, into the opposite end of the adapter housing. Ensure the bearing cups are fully seated in the back of the adapter housing recesses.

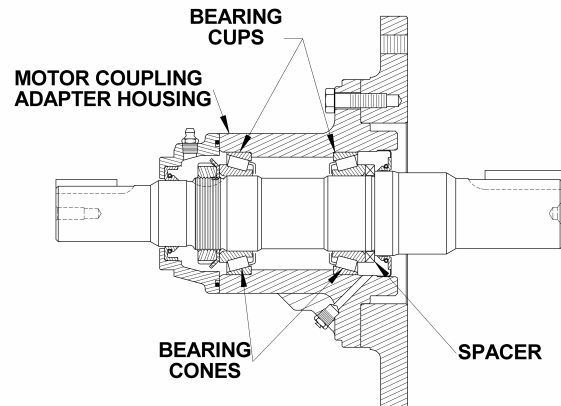
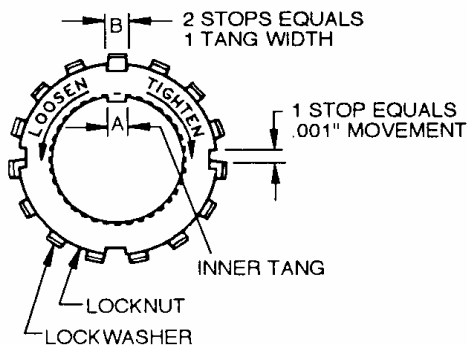

Figure 2 – Motor Coupling Adapter Assembly

# MAINTENANCE

- Slide a spacer (82) over the “driven” end (smaller end) of the motor coupling adapter shaft; followed by the bearing cone, tapered and outward.
- Insert the shaft (125) into the outboard end flanged end of the adapter housing.
- On the opposite end of the housing, slide the bearing cone with the tapered end inward into the housing recess.
- Slide the bearing lockwasher (24B), tangs outward, over the shaft.
- With the tapered end inward, thread the bearing locknut (24A) clockwise onto the shaft threads.
- The purpose of the bearing locknut and lockwasher is to seat the bearing cones in their respective cups.

**Overtightening the locknut can cause bearing failure or a broken lockwasher tang (see “A” on Figure 3). A loose locknut will allow the shaft to shift, causing excessive bearing wear, and possible damage to the pump magnet.**



**Figure 3 - Bearing Locknut Adjustment**

## Locknut Adjustment Procedure:

- Using a spanner wrench fully tighten the locknut to ensure that the bearing cones are seated in bearing cups. *Use care not to bend or shear the inner tang.*
  - After seating the bearings, loosen the locknut one complete turn.
  - Tighten the locknut until a slight drag is felt when turning the shaft by hand.
  - Back off the nut the width of one lockwasher tang “B” or two stops (see Figure 3). Secure the locknut by bending the closest aligned lockwasher tang into the locknut slot. Ensure that the shaft turns freely when rotated by hand.
- Press the grease seal (104) into the bearing cover with the flat side inward, so that the lips of the seal will face towards the housing when the bearing cover is installed.
  - Install a new bearing cover o-ring (26) and the bearing cover (27A) to the housing. Install and tighten the two bearing cover capscrews (28) torquing to 15 lbs ft (20 Nm).
  - On the opposite end, press a new grease seal (104A) over the shaft with the lip inward, into the recess of the housing.
  - After reassembly of the motor coupling adapter, follow the instructions under “Motor Coupling Adapter Installation” in this manual.

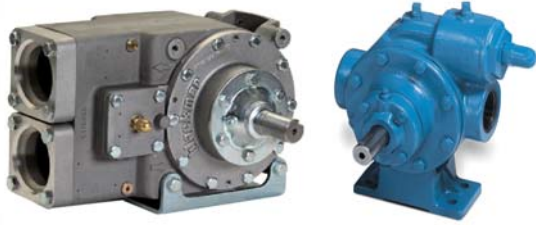

Sliding Vane Pumps: 5 to 2200 GPM  
Refined Fuels, Liquefied Gases, Process,  
Transport, Marine

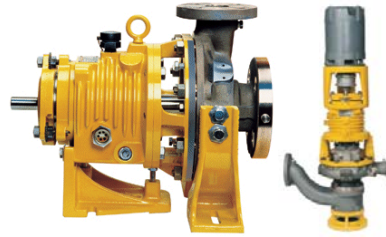

System One Centrifugal Pumps  
10 to 7500 GPM  
Process, Marine



C-Series Eccentric Disc Pumps  
1 to 150 GPM  
Shear Sensitive, Food, Process



Abaque Peristaltic Hose Pumps  
0.5 to 220 GPM  
High Lift, Solids, Abrasives



Rotary Vane and Screw Compressors  
Dry Bulk Unloading



Reciprocating Gas Compressors  
Liquefied Gas Transfer, Boosting, Vapor Recovery



Hydraulic Coolers  
Complete Packages



Magnetic Drive Pumps  
Iron and Stainless, 14 to 333 GPM



Hand Operated Pumps  
Dispensing, Transfer, In-line



Accessories  
Gear Reducers, Bypass Valves, Strainers

