

# BLACKMER DMX III AIR/RELIEF VALVE CONVERSION KIT

964602  
Page 1 of 8

INSTRUCTIONS  
AND PARTS LIST  
NO. 201B-B00

INSTALLATION OPERATION AND MAINTENANCE INSTRUCTIONS & PARTS LIST

**For Pump Models:  
TXD2A-DMXAV, TXD2.5A-DMXAV, TXD3E-DMXAV**

Section Effective Replaces	201B April 2007 February 2003
----------------------------	-------------------------------------

TABLE OF CONTENTS	Page
<b>SAFETY DATA</b> .....	1-2
<b>VALVE DATA</b> .....	2
Air / Relief Valve Technical Data .....	2
Initial Air / Relief Valve Settings.....	2
<b>INSTALLATION</b> .....	2
Pre-Installation Cleaning .....	2
Mounting the Air / Relief Valve .....	3
Air / Relief Valve Adjustment.....	3
<b>TANK TRUCK FUEL OIL DELIVERY OPERATION</b>	4
<b>MAINTENANCE</b> .....	5
Maintenance and Inspection Schedules.....	5
Air / Relief Valve Removal and Disassembly .....	5
Air / Relief Valve Assembly .....	5
<b>PARTS LIST</b> .....	7

**NOTICE:**  
Review and follow all hazard warnings provided in the appropriate Blackmer pump installation, operation and maintenance instruction manual

NOTE: Blackmer pump manuals & parts lists may be obtained from Blackmer's website (www.blackmer.com) or by contacting Blackmer Customer Service

PUMP MODEL	PUMP INSTRUCTION MANUAL	PUMP PARTS LIST		
		2"	2.5"	3"
TXD	201-A00	201-A02	201-A03	201-A04

NOTE: Numbers in parentheses following individual parts indicate reference numbers on Blackmer Parts List

## SAFETY DATA



**This is a SAFETY ALERT SYMBOL.**

When you see this symbol on the product, or in the manual, look for one of the following signal words and be alert to the potential for personal injury, death or major property damage



Warns of hazards that WILL cause serious personal injury, death or major property damage.



Warns of hazards that CAN cause serious personal injury, death or major property damage.



Warns of hazards that CAN cause personal injury or property damage.

**NOTICE:**

Indicates special instructions which are very important and must be followed.

**NOTICE:**

Blackmer DMX Air/Relief Valves **MUST** only be installed in systems which have been designed by qualified engineering personnel. The system **MUST** conform to all applicable local and national regulations and safety standards.

This manual is intended to assist in the installation and operation of the Blackmer DMX Air/Relief Valves, and **MUST** be kept with the system.

Blackmer DMX Air/Relief Valve service shall be performed by qualified technicians **ONLY**. Service shall conform to all applicable local and national regulations and safety standards.

Thoroughly review this manual, all instructions and hazard warnings, **BEFORE** performing any work on the Blackmer DMX Air/Relief Valves.

Maintain **ALL** system and Blackmer truck pump operation and hazard warning decals.

# SAFETY DATA

**⚠ WARNING**



Hazardous machinery can cause serious personal injury or property damage.

Failure to set the vehicle emergency brake and chock wheels before performing service can cause severe personal injury or property damage.

**⚠ WARNING**



Hazardous pressure can cause personal injury or property damage.

Disconnecting fluid or pressure containment components during pump operation can cause serious personal injury, death or major property damage

**⚠ WARNING**



Hazardous machinery can cause serious personal injury.

Failure to disconnect and lockout electrical power or engine drive before attempting maintenance can cause serious personal injury or death

**⚠ WARNING**



Hazardous or toxic fluids can cause serious injury.

If pumping hazardous fluids system must be flushed and decontaminated prior to performing service or maintenance.

**⚠ WARNING**



Hazardous fluids can cause fire, serious personal injury or property damage.

All fluids pumped must be compatible with diaphragm material. Incompatibility can cause fire, serious personal injury or property damage.

**⚠ WARNING**



Hazardous pressure can cause serious personal injury or property damage.

Failure to relieve system pressure prior to performing pump service or maintenance can cause personal injury or property damage.

**NOTICE:**

Installation and maintenance should be performed by qualified technicians only, following the appropriate procedures and warnings as presented in this manual and the appropriate pump installation, operation, and maintenance instructions.

## VALVE DATA

**AIR / RELIEF VALVE TECHNICAL DATA**

Maximum Air Pressure	125 psi (8.6 Bar)
Minimum Air Pressure	35 psi (2.4 Bar)
Maximum Operational Temperature	240°F (115°C)
Minimum Operational Temperature	-20°F (-29°C)

**INITIAL AIR / RELIEF VALVE SETTINGS**

Pump Operating Pressure:	_____
Low Pressure Setting:	_____
High Pressure Setting:	_____
Peak Pressure Setting:	_____

## INSTALLATION

The Blackmer DMX air/relief valve is diaphragm type relief valve. The air/relief valve is designed to work with a fluid flow detector, which controls the pneumatic air pressure behind the diaphragm when the nozzle is open and fluid is flowing. This permits high pressure operation of the pump. When the nozzle is closed and flow is stopped, the flow detector pilot valve vents the actuating air from behind the diaphragm and the pump will automatically go into low pressure bypass.

Approximately 35 psi (2.5 bar) minimum air pressure is required to properly operate the air valve control system. Air pressure MUST NOT exceed 125 psi (8.6 bar).

**PRE-INSTALLATION CLEANING**

Foreign matter entering the DMX or pump WILL cause extensive damage. The pump and the surrounding area MUST be cleaned prior to attempting air/relief valve installation. The supply tank and intake piping MUST be cleaned and flushed prior to installation and operation.

# INSTALLATION

## NOTICE:

The Blackmer DMX air/relief valve is designed for fuel oil service. Contact factory for all other fluids.

## NOTICE:

A preset, spring loaded air check valve must be installed in the vehicle air supply line to ensure minimum safe air pressure for the brake system.

## MOUNTING THE AIR/RELIEF VALVE

1. Remove the pump relief valve cap (1) and turn the adjusting screw (2) counterclockwise to relieve spring tension.
2. Remove and discard the pump's four relief valve cover bolts (5 & 5C). Remove the cover assembly (4), spring guide (7), spring (8), and gasket (10). Clean and inspect the gasket surfaces, repairing as necessary.
3. Install a new gasket (10).
4. Attach the Blackmer DMX Air/Relief Valve Conversion Kit to the pump using the four new bolts provided (5 & 5C). Ensure the valve cover (4) is positioned so that the air inlet pipe hole is accessible to attach the air line.
5. Torque the air valve mounting bolts as indicated in Table 1.

PUMP MODEL	TORQUE * - lbs in (Nm)
TXD2A-DMXAV	150(16.9)
TXD2.5A-DMXAV	175 (19.8)
TXD3E-DMXAV	225 (25.4)

\*Torque specification tolerance is +/- 10 lbs in (1.08 Nm).

Table 1

## AIR/RELIEF VALVE ADJUSTMENT



**Failure to relieve system pressure prior to performing pump service or maintenance can cause personal injury or property damage.**



**Incorrect settings of the Blackmer DMX air/relief valve can cause system component failure, personal injury and property damage.**

The pump mounted Blackmer DMX air/relief valve low and high pressure settings are adjustable within a specific range to suit the engine operating speed and conditions. Air valve adjustment is done by adjusting the regulators in the Air Control Panel. Refer to Table 2 for the air valve pressure settings.

Attach a suitable pressure gauge at the pump discharge gauge port (73) to make the required air valve adjustments. Record the air valve and pump operating pressures in the "Initial Air Valve settings" Chart on page 2 of this manual.

PRESSURE	SETTING / RANGE – PSI (bar)
<b>Pump Operating</b>	100 (6.9) Maximum
<b>Low</b>	10-35 (.69 –2.4)
<b>High</b>	70-125 (4.8-8.6); 125 (8.6) Maximum
<b>Peak</b>	15-25 (1.0-1.7) above normal operating pressure

Table 2

## Low Pressure Adjustment:

The air valve low pressure adjustment MUST be set first.

## NOTICE:

**The air valve low pressure setting regulates the delivery hose pressure when the nozzle is closed. Adjust the air valve only high enough to open the flow detector/check valve.**

1. Adjustment MUST be made with the pump at normal idle speed - 200 RPM minimum.
2. SLOWLY close the delivery nozzle, allowing the pump pressure to be relieved. Note the gauge pressure reading.
3. Lift the adjusting handle on the low pressure regulator in the Air Control Panel to allow air regulator setting adjustment. Turn the low pressure air regulator clockwise to increase the pressure setting, or counterclockwise to decrease the pressure setting. Refer to Table 2 for recommended setting ranges. **NOTE:** The low pressure regulator is factory set at 35 PSI (2.4 bar).
4. After setting the air regulator pressure, push down on the adjusting knob to lock into position.
5. Open and close the delivery nozzle several times to ensure the correct setting. Repeat steps 2 - 4 until the required low pressure setting is achieved.

## High Pressure Adjustment:

1. Adjustment MUST be made with the pump at normal operating speed and with pressure behind the air valve diaphragm.
2. SLOWLY close the delivery nozzle, allowing the pump pressure to be relieved. Note the gauge pressure reading.
3. Lift the adjustment knob on the high pressure regulator in the Air Control Panel to allow air regulator setting adjustment. Turn the high pressure air regulator clockwise to increase the pressure setting, or counterclockwise to decrease the pressure setting. Refer to Table 2 for recommended setting ranges. **NOTE:** The high pressure regulator is factory set at 70 psi (4.8 bar).

## NOTICE:

**To avoid damage to the diaphragm (9c) do not overpressure the diaphragm.**

4. After setting the air regulator pressure, push down on the adjusting knob to lock into position.
5. Open the delivery nozzle and observe the pump's discharge gauge. Repeat steps 2-4 until required high pressure setting is achieved.
6. After the final adjustment is made, ensure that the air regulator adjustment knobs are pushed down and locked into position. Close and lock the Air Control Panel box using the attached latch. Inspect all air lines for leaks and replace as necessary.

## NOTICE:

**Where regulations require, holes in R/V cap (1) and capscrew with hole (5C) are used by the Weights and Measures official(s) to apply a security seal or tag.**

# TANK TRUCK FUEL OIL DELIVERY SYSTEM

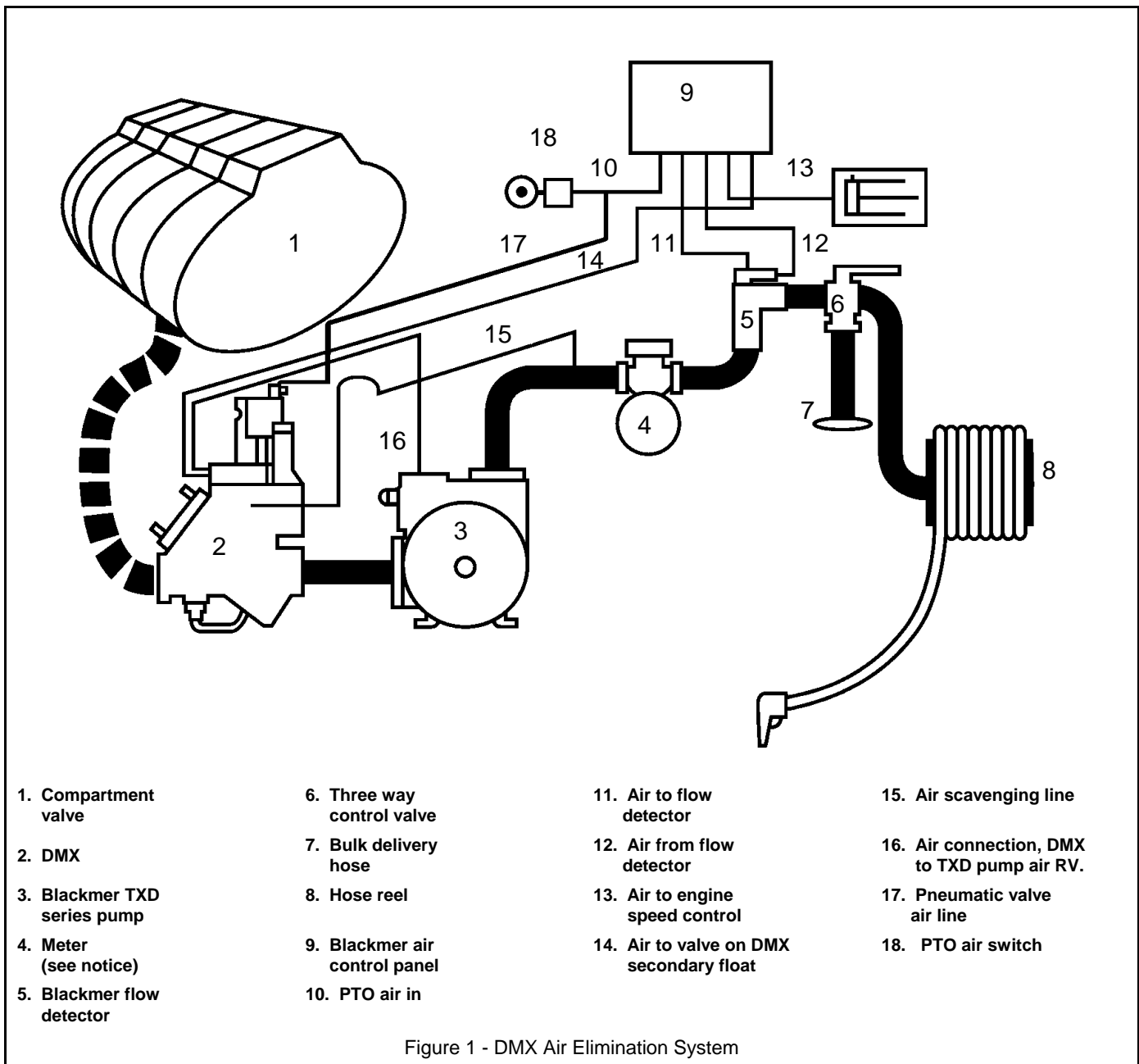

## NOTICE:

Refer to meter manufacturer's recommendations regarding installation of strainers after the pump.

The pump is equipped with an adjustable pneumatic actuated air/relief valve controlled by the DMX System. With regulated and properly adjusted air pressure on the diaphragm, the pump relief valve controls pressure in the conventional manner. When air pressure is removed, the air/relief valve opens wide, reducing the system liquid pressure.

When the nozzle is opened, the flow detector senses liquid flow and actuates an air signal to the DMX and engine speed control. The engine and pump speed increases to the preset level and the pump is pressurized to the air valve setting regulated by the air control panel increasing system pressure. The result is the desired flow at a preset pressure.

When the nozzle closes, the flow detector senses no liquid flow and removes the air pressure from DMX, pump air valve and engine speed control. With no air pressure, the system reduces the engine and pump speed to the low speed settings. Reduced system pressure allows for easier hose handling. The net effect is reduced wear and tear on the equipment.

The nozzle may be partially closed to "top off" a tank in the same manner as when a Blackmer pump with the standard relief valve is used. The Blackmer Flow Detector allows the "top off" flow rate to be adjusted to a desired rate. Refer to Flow Detector Instructions for adjustment procedure.

The engine speed control air cylinder should be rigidly mounted to prevent variations in the speed control.

# MAINTENANCE

## NOTICE:

Maintenance should be performed by qualified technicians only, following the appropriate procedures and warnings as presented in this manual and the appropriate pump installation, operation, and maintenance instructions.

**⚠WARNING**



Hazardous machinery can cause serious personal injury or property damage.

Failure to set the vehicle emergency brake and chock wheels before performing service can cause severe personal injury or property damage.

**⚠WARNING**



Hazardous machinery can cause serious personal injury.

Failure to disconnect and lockout electrical power or engine drive before attempting maintenance can cause serious personal injury or death.

**⚠WARNING**



Hazardous fluids can cause fire, serious personal injury or property damage.

All fluids pumped must be compatible with diaphragm material. Incompatibility can cause fire, serious personal injury or property damage.

**⚠WARNING**



Hazardous pressure can cause personal injury or property damage.

Disconnecting fluid or pressure containment components during pump operation can cause serious personal injury, death or major property damage.

**⚠WARNING**



Hazardous or toxic fluids can cause serious injury.

If pumping hazardous fluids system must be flushed and decontaminated prior to performing service or maintenance.

**⚠WARNING**



Hazardous pressure can cause serious personal injury or property damage.

Failure to relieve system pressure prior to performing pump service or maintenance can cause personal injury or property damage.

## DMX AIR / RELIEF VALVE MAINTENANCE AND INSPECTION SCHEDULES

Valve Assembly Part	Inspection Schedule	Action Required
Vent Plate (6A)	Weekly	If leakage is present, IMMEDIATE valve service is required. DO NOT remove grease from vent hole.
Air Valve Assembly	Annually	Disassemble, inspect diaphragms and replace if cracked or blistered.
Diaphragm (9C)	3 Years (or less)	REPLACE

## DMX AIR / RELIEF VALVE REMOVAL AND DISASSEMBLY

1. Remove the cap (1) from the air valve assembly. Remove and discard the cap O-ring (88).
2. Remove the four capscrews (5 & 5C) and lockwashers (5B).
3. Carefully remove the DMX air/relief valve assembly, and if necessary, the valve (9).
4. Remove and discard the gasket (10). Clean gasket areas.
5. Remove the two machine head screws (5A), valve plate (6), diaphragm assembly (9C), and vent plate (6A). Discard the diaphragm assembly.

## DMX AIR / RELIEF VALVE ASSEMBLY

### NOTICE:

Prior to assembly, the area around the spacer between the diaphragms and the inner diameter of the vent plate must be greased with a lithium based grease. Remove any grease from the outer diameter of the vent plate and diaphragm surfaces.

1. Being careful not to damage the diaphragm, place the vent plate (6A) between the two diaphragms by pulling the pump side diaphragm corners through the center hole in the vent plate.
2. Insert the new diaphragm assembly into the valve cover.
3. Install the plate (6) on the air valve with the holes in the diaphragm, vent plate and plate lined up. Attach the assembly with the two machine screws (5A), tightening securely.
4. Install a new gasket (10) and insert the four capscrews (5 & 5C) with lockwashers (5B) into the air valve assembly.

### NOTICE:

The follower attached to the diaphragm assembly (9C) must fit over the boss on the relief valve (9).

5. If removed, reinstall the relief valve (9). Place the follower attached to the diaphragm assembly over the boss on the relief valve (9). Mount the air valve assembly to the pump, ensuring that the gasket is properly seated. Torque the capscrews (5 & 5C) to the appropriate value  
(See Table 1).
6. With a new O-ring (88) installed, attach the air valve cap (1) securely.
7. Adjust the new air valve as provided in the "Air/Relief Valve Adjustment" section of this manual.

---

## NOTES

## PARTS LIST

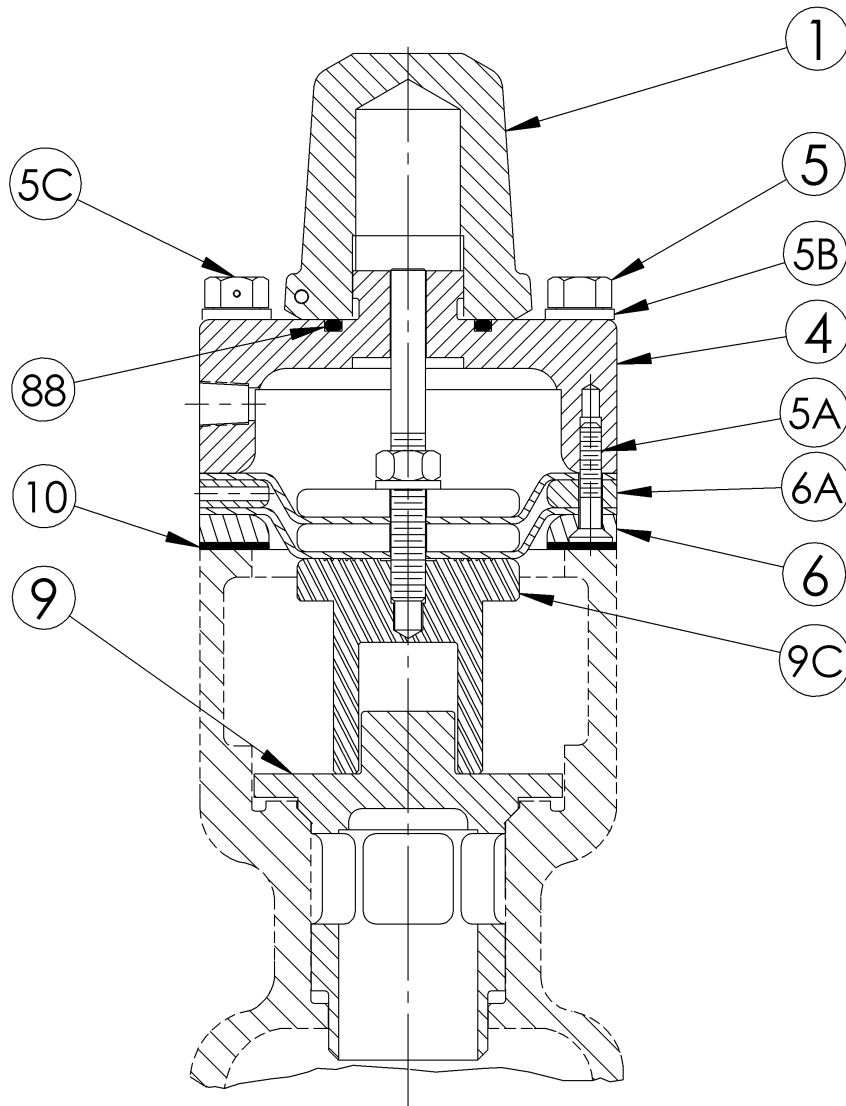

REF. NO.	PART NAME	PARTS PER VALVE	TXD2A-DMXAV PART NO.	TXD2.5A-DMXAV PART NO.	TXD3E-DMXAV PART NO.
1	Cap	1	411754	411754	411754
4	Cover	1	411711	411713	411715
5	Capscrew	3	920444	920444	920444
5A	Machine Screw	2	922216	922216	922216
5B	Lockwasher	4	909649	909649	909649
5C	Capscrew w/ Hole	1	920433	920433	920433
6	Plate	1	701400	701735	701737
6A	Vent Plate	1	701418	701618	701818
9	Valve **	1	451417	451623	451807
9C	Diaphragm Assembly	1	874611	874613	874615
10	Gasket	1	531403	531603	531803
88	O-Ring	1	711917	711917	711917
	DMX A/V Conversion Kit	—	894611	894613	894615

\* Valves are NOT included in DMX A/ V Conversion Kits

