



STX3 Series

Stainless Steel Transport Pump

Design

Blackmer's STX3 is made from 316 stainless steel with external ball bearings, non-metallic Duravanes, Teflon® elastomers, and Blackmer chemical mechanical seals. The STX3 has an adjustable relief valve, versatile mounting bracket and is self-priming.

Application

The STX3 offers flow rates up to 250 gpm (946 lpm) with differential pressures up to 125 psi (8.6 bar) and maximum speed of 800 rpm. The STX3 typical applications are solvents, chemicals, sulfates, vegetable oils, urea and many acids.

Benefit

Blackmer's STX3 offers fast fluid off-loading. A typical off-loading of a 6,000 gallon (22,700 liter) tanker can be unloaded as quickly as 24 minutes.

Blackmer's non-metallic vanes self-compensate for wear and allow the STX3 to run dry for short periods of time for self-priming and blowing lines clean, with out pump damage.

Blackmer's STX3 is designed to offer easy maintenance because the internal wear is limited almost completely to the sliding vanes, which can be replaced with ordinary metric hand tools.



STX3

How Blackmer's sliding vane action works

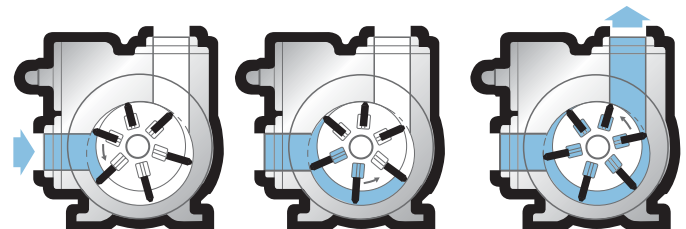



STX3 Series Stainless Steel Transport Pump

Characteristic Flow Rates

Pump Speed	Pump Capacity @ 50 psid (3.45 bar) with 100 ssu (22 cSt) Fluid			Maximum Fluid Viscosity at rpm Shown	
	US gpm	lpm	m ³ /h	ssu	cSt
800	250	946	56	500	105
700	220	832	50	500	105
600	190	719	43	5,000	1,050
500	150	576	34	10,000	2,200
400	125	473	28	20,000	4,250

Application Assistance

In some applications, selecting the right pump may require more detailed information than can be presented in this Spec Sheet. Blackmer has a worldwide distribution network to assist in specifying the proper pump for your application.

Please contact Blackmer's Application Group at the telephone or fax number listed below for the name of your nearest Blackmer distributor.

Options

Hydraulic drive packages: fully integrated, factory engineered hydraulic drive packages custom matched to the application, along with Blackmer's Hydrive cooler are also available.

Pump Horsepower Requirements

Pump Speed	50 ssu (13 cSt) Viscosity		500 ssu (105 cSt) Viscosity		5,000 ssu (1,050 cSt) Viscosity		10,000 ssu (2,200 cSt) Viscosity		20,000 ssu (4,250 cSt) Viscosity	
	50 psi (3.45 bar)	100 psi (6.9 bar)	50 psi (3.45 bar)	100 psi (6.9 bar)	50 psi (3.45 bar)	100 psi (6.9 bar)	50 psi (3.45 bar)	100 psi (6.9 bar)	50 psi (3.45 bar)	100 psi (6.9 bar)
800	9.8	17.9	11.0	19.0	—	—	—	—	—	—
700	8.2	15.3	9.2	16.1	—	—	—	—	—	—
600	6.9	13.2	7.6	13.5	10.0	16.3	—	—	—	—
500	5.5	10.6	6.1	11.0	8.0	13.2	9.1	14.3	—	—
400	4.3	8.3	4.7	8.5	6.1	10.3	6.9	11.1	8.3	12.4

Refer to Blackmer Characteristic Curves for flow rates and torque requirements for your specific conditions.

Pump Rotation

Blackmer's STX3 pump models are equipped with a double-ended straight-keyed drive shaft for either clockwise (RH) or counterclockwise (LH) rotation.

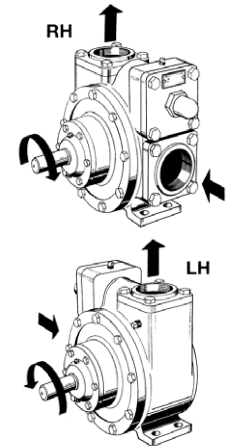

Maximum Operating Limits

Nominal Flow Rate			Pump Speed	Viscosity		Differential Pressure		Temperature ¹	
US gpm	lpm	m ³ /h		ssu	cSt	psi	bar	°F	°C
250	946	56	800	20,000	4,250	125	8.6	240	115

¹For higher temperature or viscosity conditions, consult factory.

Pump Dimensions

Pump Model	A	B	C	D	E	F	G	H	J	K	L	M	N	P	Approx. Weight	
	STX3	in.	—	—	2 1/2	9 1/2	5	11 1/2	6 1/2	6 3/4	5 1/4	3 3/4	5 3/4	8	4 3/4	2 1/4
	mm	35	10	54	242	127	283	155	159	133	95	137	203	118	57	60 kgs

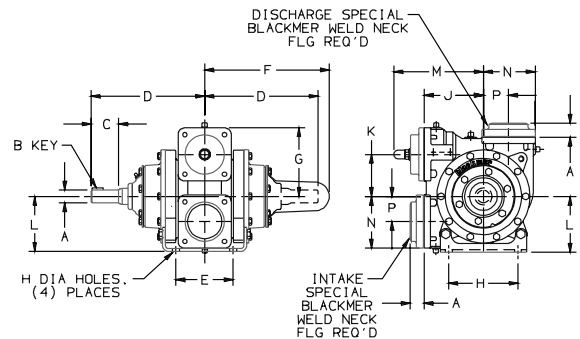

Distributed by:

