

BLACKMER V-BELT DRIVE (STYLE VB)

PUMP MODEL: LGL2E

Parts List with Installation, Operation and Maintenance Instructions

964403 **PARTS LIST**
Page 1 of 2 **501-H01**

Section 500
Effective May 2003
Replaces June 2002

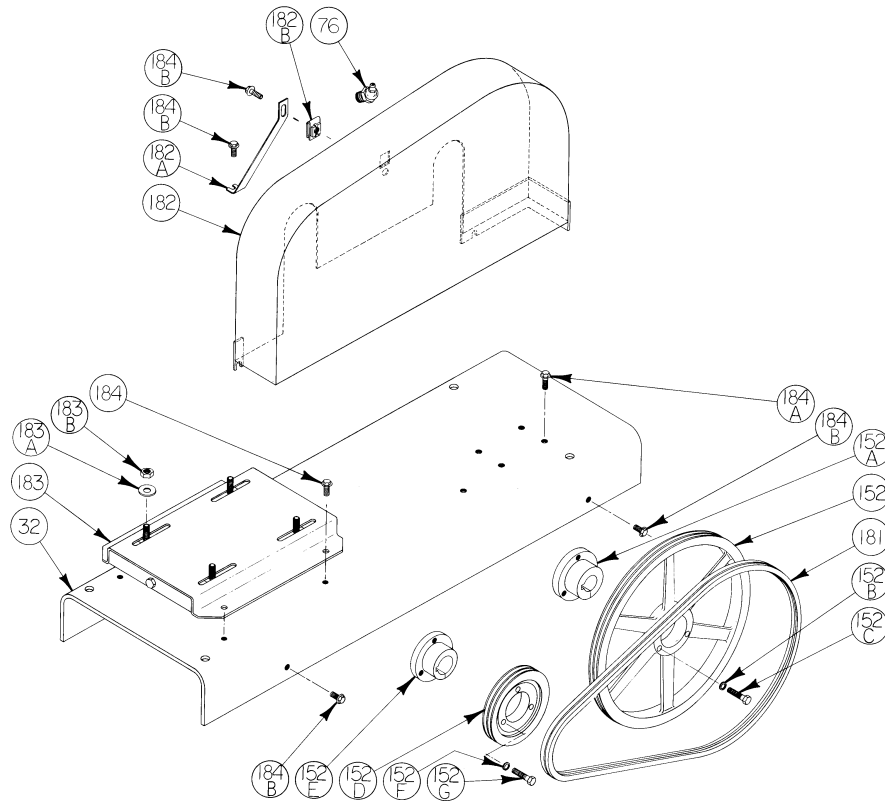

PARTS LIST

Ref. No.	Description	Parts Per Pump	Part No.	Ref. No.	Description	Parts Per Pump	Part No.
32	Pump Base	1	901941	181	V-Belt	2	See Table
76	Grease Fitting	1	317809	182	V-Belt Guard (3)	1	See Table
152	Pump Sheave	1	902405	182A	V-Belt Guard Brace	1	804076
152A	Pump QD Hub Assembly	1	902450	182B	Speed Nut	1	922407
152B	Lockwasher	3	(1)	183	Motor Base Assembly	1	See Table
152C	Capscrew	3	(1)	183A	Washer	4	(2)
152D	Motor Sheave	1	See Table	183B	Nut	4	(2)
152E	Motor QD Hub Assembly	1	See Table	184	Capscrew - Motor Base	4	920957
152F	Lockwasher	3	(1)	184A	Capscrew - Pump	4	920956
152G	Capscrew	3	(1)	184B	Capscrew - Guard	4	920955

(1) Included with QD Hub Assembly.

(2) Included with Motor Base Assembly.

(3) For ATEX Compliant (Non-Sparking) Guards, Please Consult the Factory.

V-BELT DATA - 3V TYPE BELTS

PUMP SPEED WITH 1750 RPM MOTOR		330	420	420	520	520	660	660
SPEED RATIO		5.37	4.23	4.23	3.43	3.43	2.66	2.66
MOTOR FRAME SIZE		182T	182T	184T	182T	184T	184T	213T
Ref. No.	Part Name	Part Number						
152D	Motor Sheave	902406	902407	902407	902408	902408	902409	902409
152E	Motor QD Hub Asy.	902457	902451	902451	902451	902451	902451	902453
181	V-Belt	902002	902002	902002	902002	902002	902002	902006
182	V-Belt Guard (3)	804060	804060	804060	804060	804060	804060	804061
183	Motor Base Asy.	905081	905081	905082	905081	905082	905082	905083

INSTALLATION AND MAINTENANCE

THESE UNITS MUST ONLY BE INSTALLED IN SYSTEMS WHICH HAVE BEEN DESIGNED BY THOSE QUALIFIED TO ENGINEER THESE SYSTEMS. THE SYSTEM MUST BE IN ACCORDANCE WITH ALL APPLICABLE REGULATIONS AND SAFETY CODES.

ASSEMBLY

Mount the pump and the motor base to the unit base. Mount the motor on the motor base, but do not draw the motor mounting nuts down tight.

Wipe the cone surface of the pump QD hub and the inside of the pump sheave hub with a clean cloth moistened with a light grade of machine oil. This will allow a more uniform draw and prevent the cone surfaces from "freezing" before being tightened.

With the shaft key in place, align the key seat and slide the QD hub on the shaft, flange end first. Slide the large end of the sheave bore over the taper on the QD hub. Insert the three (3) sheave capscrews through the clearance holes in the sheave, and start them into the tapped holes of the QD hub. Repeat this procedure to assemble the motor QD hub and sheave.

To install the belts, shorten the center distance of the drive by moving the motor towards the pump, until the belts can be put on the sheaves without forcing.

Align the sheaves so that the faces are parallel, then snug up the sheave capscrews.

Measure the span length as shown in Figure 1.

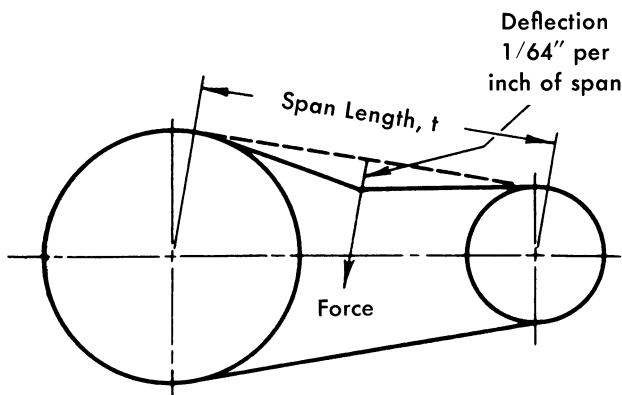

Figure 1

Adjust the motor base and apply a specified force (as shown in Table 1) against the belt, at the center of the span, so that the belt is deflected 1/64 inch for every inch of span. For example, the deflection of a 20 inch span would be 20/64 or 5/16 inch. The force required should be within the range given in Table 1 for a properly tensioned drive. A new set of belts should initially be tensioned to the upper limit. Check again to see that the sheaves are parallel and then tighten the sheave capscrews, the motor mounting nuts and the adjusting screw locknut. Assemble the belt guard and the belt guard brace to the unit base.

DEFLECTION FORCE PER BELT

SMALL SHEAVE OUTSIDE DIAMETER	BELT DEFLECTION FORCE	
	Minimum	Maximum
2.5" to 4.5" (63.5 mm to 114.3 mm)	3.0 Lbs. (1.4 Kg.)	4.75 Lbs. (2.2 KGB.)
4.75" to 7" (120.7 mm to 177.8 mm)	4.0 Lbs. (1.8 KGB.)	6.0 Lbs. (2.7 KGB.)

Table 1

Check the belt tension after 24 - 48 hours run-in. Recheck the tension periodically, and tighten the belts as required. Caution should be used to avoid overtightening belts, which can shorten bearing and belt life. Belts should be inspected periodically for signs of excessive wear and replaced if necessary.

For information on system installation and pump maintenance refer to the Installation and Maintenance Instructions provided with the pump.

DISASSEMBLY

Remove the belt guard and the guard brace. Loosen the adjusting screw locknut on the motor base and the motor mounting nuts. Ease the tension on the belts by moving the motor towards the pump to shorten the center distance of the drive. Remove the belts by sliding them over the sheaves. Do not force the belts over the grooves.

To remove the sheave from the hub, first remove the three sheave capscrews, then screw two of them into the threaded holes in the sheave hub. If the cone grip is hard to break loose, tap the end of the shaft or the QD hub with a lead hammer, while maintaining pressure on the screw.

The QD hub should slide smoothly off the shaft. If it is tight on the shaft, pry it loose with a screwdriver or a small wedge placed in the split part of the flange.

