

BLACKMER PARTS LIST

PUMP MODELS: CRL2, CRL3 OBSOLETE MODELS: TCRL2, TCRL3

(See Instructions 701-B00 for Installation, Operation and Maintenance)

964481 **PARTS LIST**
Page 1 of 2 **701-B01**

Section | 701
Effective | Mar 2005
Replaces | July 2002

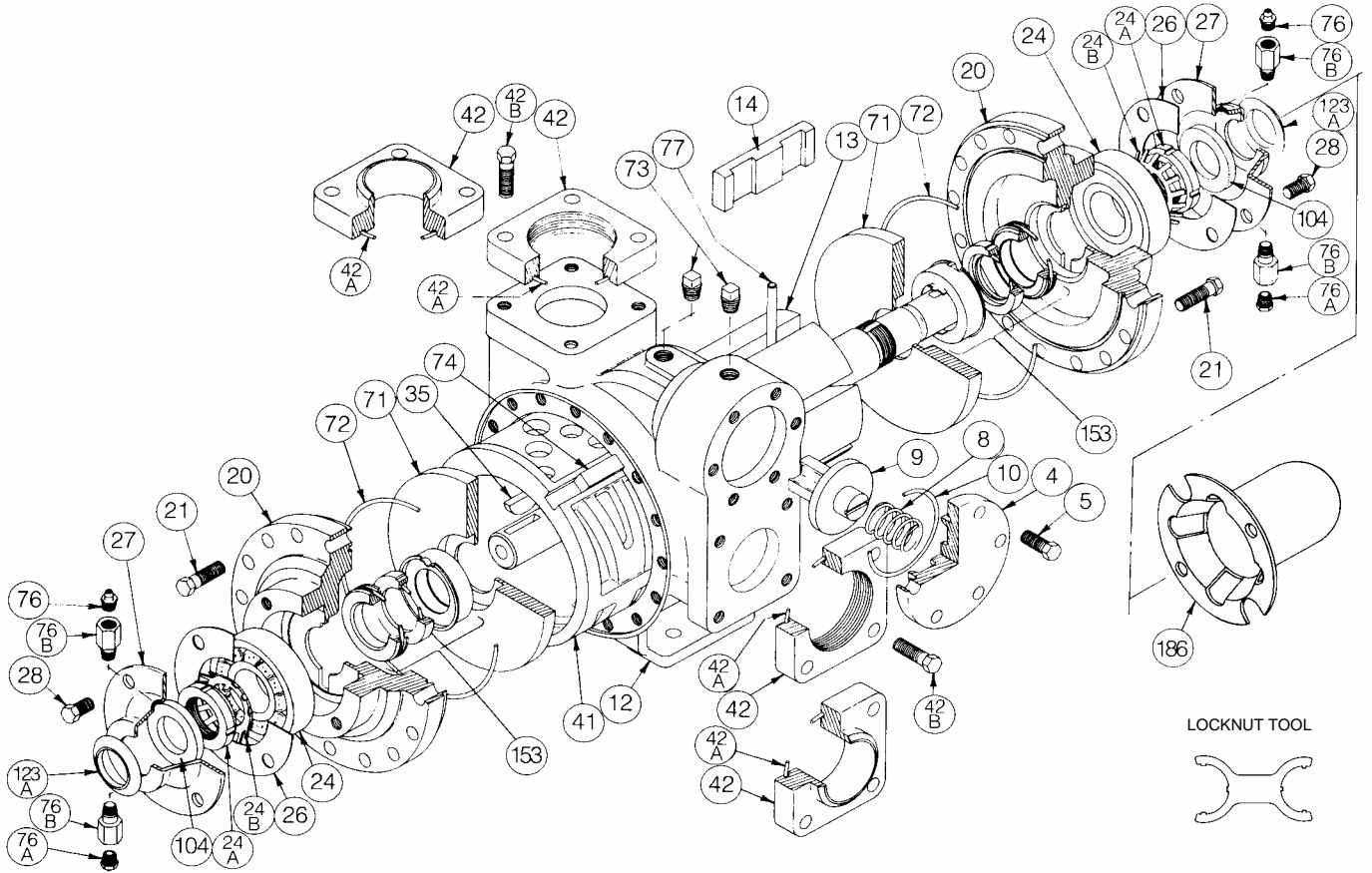

Ref. No.	Description	Parts per Pump	Size 2 Part No.	Size 3 Part No.	Ref. No.	Description	Parts per Pump	Size 2 Part No.	Size 3 Part No.
4	Relief Valve (R/V) Cover	1	414401	415113	42	Flange – NPT	2	654401	655112
5	R/V Cover Capscrews	6	920331	920331	42	Flange – Weld	2	654405	655102
8	R/V Spring (150 psi)	1	471423	475135	42A	O-Ring – Flange	2	¹ 702004	¹ 702002
9	R/V Valve	1	454405	455129	42B	Capscrew – NPT Flange	8	920384	920547
10	O-Ring – R/V Cover	1	¹ 701919	¹ 701925	42B	Capscrew – Weld Flange		920351	920510
12	Casing	1	014405	015127	71	Disc	2	² 064412	² 065112
13	Rotor & Shaft Asy. ³ (Includes Ref. No. 24A & 24B)	1	² 264445	² 265148	72	O-Ring – Head	2	¹ 702022	¹ 702041
14	Vane – Laminate	6	¹ 091427	¹ 095109	73	Gage Plug	2	908198	908198
20	Head	2	034416	035128	74	Liner Key	1	^{2,4} 183991	² 185191
21	Head Capscrews	32-40	920351	920369	76	Grease Fitting	2	317815	317815
24	Bearing	2	¹ 903156	¹ 903172	76A	Grease Relief Fitting	2	701992	701992
24A	Bearing Locknut	2	² 903521	² 903523	76B	Extension Coupling	4	701905	701905
24B	Bearing Lockwasher	2	¹ 903522	¹ 903524	77	Push Rod	3	¹ 123905	¹ 125105
26	Bearing Cover Gasket	2	¹ 383940	¹ 385125	104	Grease Seal	2	¹ 331918	¹ 331908
27	Bearing Cover	2	041431	041815	123A	Dirt Shield	2	¹ 701480	N/A
28	Bearing Cover Capscrews	8-12	920285	920285	186	Shaft Protector	1	341601	341801
35	Shaft Key	1	¹ 909130	¹ 909130		Tool - Locknut		903091	903091
41	Liner	1	² 184405	² 185111		Kit - Maintenance		898905	898906
						Kit - Rebuild		899005	899006

¹ Included in Maintenance Kit and Rebuild Kit

² Included in Rebuild Kit

³ Double Ended Rotor & Shaft

⁴ Pump models before January 1995 require key PN 184407

Keep this parts list with Installation, Operation and Maintenance Instructions.

MECHANICAL SEAL

Ref. No.	Part Name	Parts Per Pump	Size 2 Part No.	Size 3 Part No.
153	Mechanical Seal Assembly (CELE)	2	¹ 334414	¹ 335132
153A	Stationary Seat (Carbon)	2	**	**
153B	Seal Face (Silicon Carbide)	2	**	**
153C	Seal Jacket Assembly	2	**	**
153D	O-Ring – Stationary (Special-EPDM)	2	702354	702355
153E	O-Ring – Rotating (Special-EPDM)	2	702352	702353

¹ Included in Maintenance Kits and Rebuild Kits

** Mechanical Seal Asy. (Ref. No. 153) is only sold as a complete assembly. Ref. Nos. 153A/153B/153C are not available as separate replacement parts.

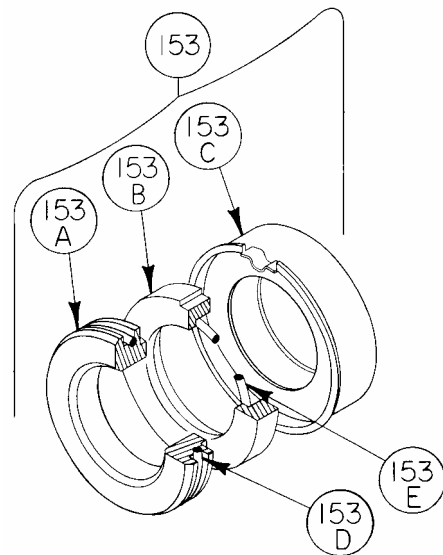

OPTIONAL HYDRAULIC MOTOR ADAPTER PARTS

Ref. No.	Part Name	Parts Per Pump	Size 2 Part No.	Size 3 Part No.
See Below	Hydraulic Motor Adapter Kit *	See Below	894425	895140
26A	Gasket- Hydraulic Motor Adapter	1	383940	381817
28A	Capscrew – Hydraulic Motor Adapter / Head	4 / 6	920369	920369
34	Coupling w/ Setscrew – for 1.25" straight key hyd. motor shaft	1	906967	906967
35	Key – Coupling	1	909184	909184
76	Grease Fitting	1	317815	317815
76A	Grease Relief Fitting	1	701992	701992
135	Hydraulic Motor Adapter – SAE A Flange	1	041827	041831
135A	Capscrew – Adapter / Motor	2	920510	920510

* Hydraulic Motor Adapter Kits shipped prior to Spring 2002 were of a two piece design – refer to page 206-D00

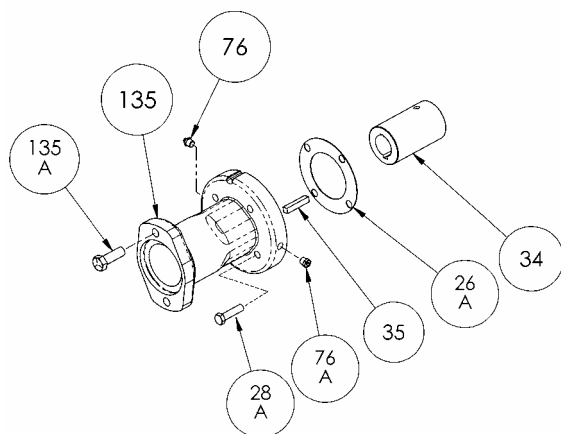

CRL2

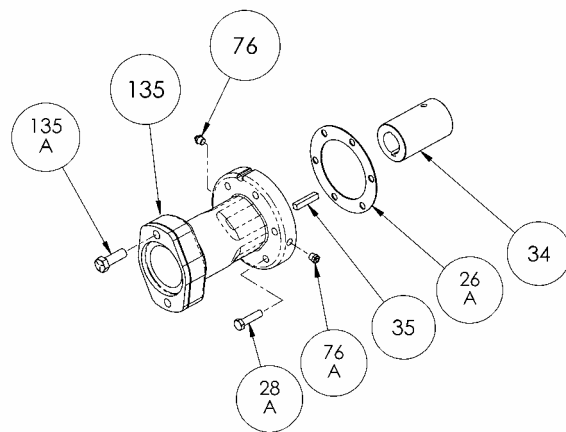

CRL3

