

BLACKMER PARTS LIST

With Installation and Maintenance Instructions V-BELT DRIVE (STYLE VB) MODEL: SGLD3

965105 **PARTS LIST**
Page 1 of 2 **801-D00**

Section 801
Effective May 2003
Replaces July 2001

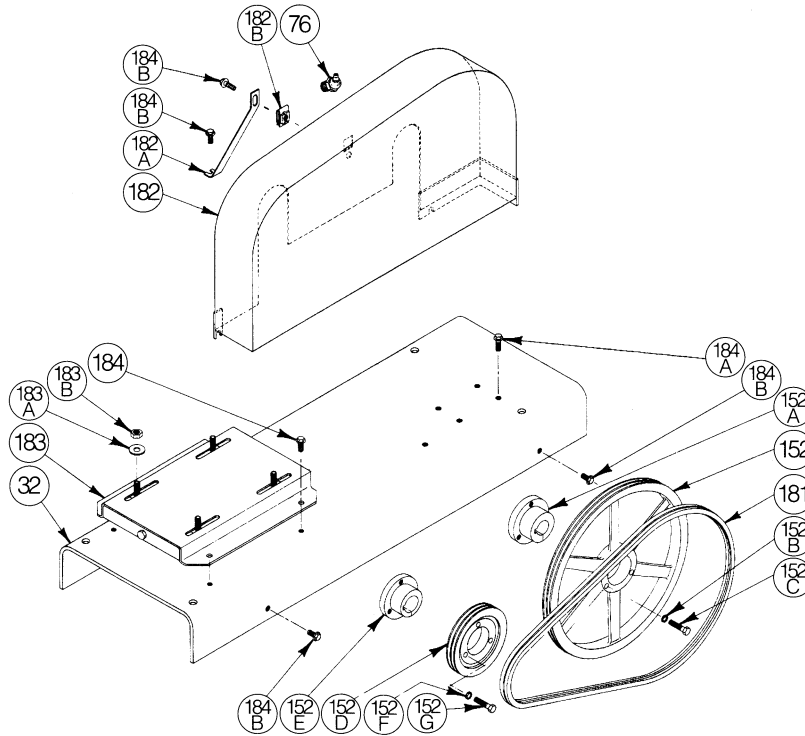

PARTS LIST

Ref. No.	Description	Parts per Unit	Part No.	Ref. No.	Description	Parts per Unit	Part No.
32	Pump Base	1	See Table	181	V-Belt	2-4	See Table
76	Grease Fitting	1	317809	182	V-Belt Guard (3)	1	See Table
152	Pump Sheave	1	See Table	182A	V-Belt Guard Brace	1	804076
152A	Pump QD Hub Assembly	1	See Table	182B	Speed Nut	1	922407
152B	Lockwasher	3	(1)	183	Motor Base Assembly	1	See Table
152C	Capscrew	3	(1)	183A	Washer	4	(2)
152D	Motor Sheave	1	See Table	183B	Nut	4	(2)
152E	Motor QD Hub Assembly	1	See Table	184	Capscrew – Motor Base	4	See Table
152F	Lockwasher	3	(1)	184A	Capscrew – Pump	4	920951
152G	Capscrew	3	(1)	184B	Capscrew – Guard	4	920955

(1) Included with QD Hub Assembly (2) Included with Motor Base Assembly

(3) For ATEX Compliant (Non-Sparking) Guards, Please Consult the Factory.

V-BELT DATA – 3V TYPE BELTS

PUMP SPEED WITH 1750 RPM MOTOR		420	420	520	520	640	640
SPEED RATIO		4.26	4.26	3.41	3.41	2.77	2.77
MOTOR FRAME SIZE		213T	215T	213T	215T	215T	254T
REF. NO.	PART NAME	PART NUMBER					
32	Pump Base	901942	901942	901942	901942	901942	901943
152	Pump Sheave	902400	902400	902400	902400	902400	902412
152A	Pump QD Hub Asy.	902450	902450	902450	902450	902450	902460
152D	Motor Sheave	902402	902402	902403	902403	902404	902413
152E	Motor QD Hub Asy.	902453	902453	902453	902453	902454	902464
181	V-Belt	902001*	902001*	902001*	902001*	902001*	902003**
182	V-Belt Guard (3)	804061	804061	804061	804061	804061	804062
183	Motor Base Asy.	905083	905084	905084	905084	905084	905085
184	Capscrew – Motor Base	920957	920957	920957	920957	920957	920958

*Two required

**Four required

INSTALLATION AND MAINTENANCE

THESE UNITS MUST ONLY BE INSTALLED IN SYSTEMS WHICH HAVE BEEN DESIGNED BY THOSE QUALIFIED TO ENGINEER SUCH SYSTEMS. THE SYSTEM MUST BE IN ACCORDANCE WITH ALL APPLICABLE REGULATIONS AND SAFETY CODES AND WARN OF ANY HAZARDS UNIQUE TO THE PARTICULAR SYSTEM.

ASSEMBLY

Mount the pump and the motor base to the unit base. Mount the motor on the motor base, but do not draw the motor mounting nuts down tight.

Wipe the cone surface of the pump QD hub and the inside of the pump sheave hub with a clean cloth moistened with a light grade of machine oil. This will allow a more uniform draw and prevent the cone surfaces from "freezing" before being tightened.

With the shaft key in place, align the key seat and slide the QD hub on the shaft, flange end first. Slide the large end of the sheave bore over the taper on the QD hub. Insert the three (3) sheave capscrews through the clearance holes in the sheave, and start them into the tapped holes of the QD hub. Repeat this procedure to assemble the motor QD hub and sheave.

To install the belts, shorten the center distance of the drive by moving the motor towards the pump, until the belts can be put on the sheaves without forcing.

Align the sheaves so that the faces are parallel, then snug up the sheave capscrews.

Measure the span length as shown in Figure 1.

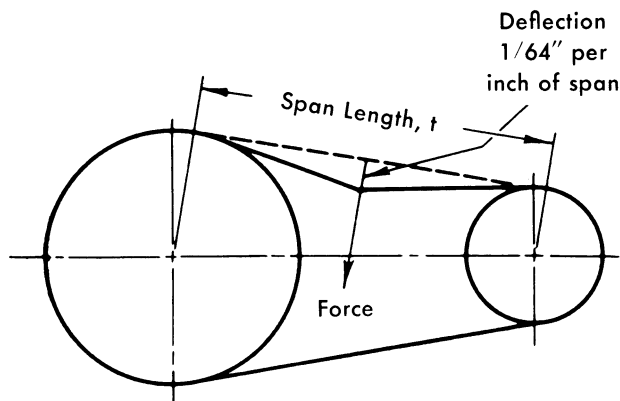

Figure 1

Adjust the motor base and apply a specified force (as shown in Table 1) against the belt, at the center of the span, so that the belt is deflected 1/64 inch for every inch of span. For example, the deflection of a 20 inch span would be 20/64 or 5/16 inch. The force required should be within the range given in Table 1 for a properly tensioned drive. A new set of belts should initially be tensioned to the upper limit. Check again to see that the sheaves are parallel and then tighten the sheave capscrews, the motor mounting nuts and the adjusting screw locknut. Assemble the belt guard and the belt guard brace to the unit base.

DEFLECTION FORCE PER BELT

SMALL SHEAVE OUTSIDE DIAMETER	BELT DEFLECTION FORCE	
	MINIMUM	MAXIMUM
2.5" to 4.5" (63.5 mm to 114.3 mm)	3.0 Lbs. (1.4 Kgs.)	4.75 Lbs. (2.2 Kgs.)
4.75" to 7" (120.7 mm to 177.8mm)	4.0 Lbs. (1.8 Kgs.)	6.0 Lbs. (2.7 Kgs.)

Table 1

Check the belt tension after 24-48 hours run-in. Recheck the tension periodically, and tighten the belts as required. Caution should be used to avoid overtightening belts, which can shorten bearing and belt life. Belts should be inspected periodically for signs of excessive wear and replaced if necessary.

For information on system installation and pump maintenance refer to the Installation and Maintenance Instructions provided with the pump.

DISASSEMBLY

Remove the belt guard and the guard brace. Loosen the adjusting screw locknut on the motor base and the motor mounting nuts. Ease the tension on the belts by moving the motor towards the pump to shorten the center distance of the drive. Remove the belts by sliding them over the sheaves. Do not force the belts over the grooves.

To remove the sheave from the hub, first remove the three sheave capscrews, then screw two of them into the threaded holes in the sheave hub. If the cone grip is hard to break loose, tap the end of the shaft or the QD hub with a lead hammer, while maintaining pressure on the screw.

The QD hub should slide smoothly off the shaft. If it is tight on the shaft, pry it loose with a screwdriver or a small wedge placed in the split part of the flange.

