

This page covers discontinued models. Jan.2002

BLACKMER PARTS LIST

PUMP MODEL: NP3E

DISCONTINUED MODEL: NP3C

NOTE: "E" model suffix indicates FKM replaces Buna-N as the standard elastomer.
(See Instructions 103-A00 or 185/F for Installation, Operation and Maintenance)

961806 **PARTS LIST**
Page 1 of 2 **103-A04_0107**

Section | 103
Effective | July 2001
Replaces | 185/F7 June95

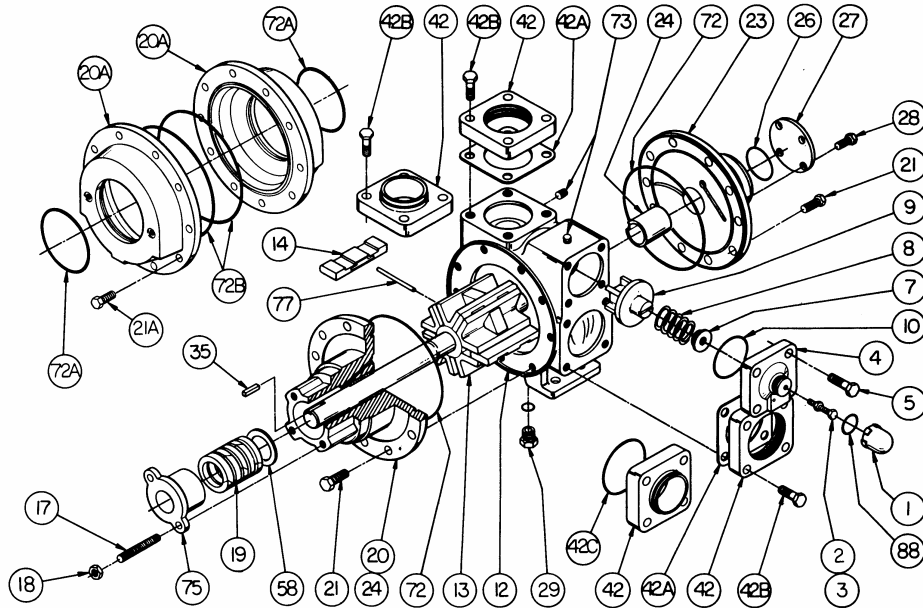
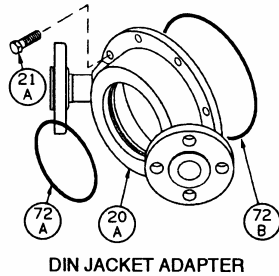

Ref. No.	Description	Parts per Pump	Part No.	Ref. No.	Description	Parts per Pump	Part No.
1	Cap - Relief Valve (R/V)	1	415000	14	Vane - EC Bronze	6	091804
2	Adjusting Screw - R/V	1	431808	20	Head & Bushing Asy. - Inboard	1	031868
3	Locknut - Adjusting Screw	1	922923	20A	SAE Heating Jacket	0 - 2	031870
4	Cover - R/V (Std.)	1	411811		Din Heating Jacket/Adapter Asy.		891750
	Cover - R/V ¹		411868	21	Capscrews - Head	20	920369
5	Capscrew - R/V Cover (Std.)	4	920331	21A	Capscrews - Heating Jacket	0 - 20	920421
	Capscrew - R/V Cover ¹		920381	23	Head & Bushing Asy. - Outboard	1	031869
7	Spring Guide - R/V	1	421805	24	Sleeve Bearing	2	161600
8	Spring - R/V (36-50 psi)	1	471805	26	O-Ring - Bearing Cover (FKM) (Std.)	1	702038
	Spring - R/V (51-110 psi)		471806		O-Ring - Bearing Cover (PTFE)		702234
	Spring - R/V (111-150 psi)		471809	27	Bearing Cover	1	041600
	Spring - R/V (151-200 psi) ¹		471868	28	Capscrews - Bearing Cover	4	920291
	SS Spring - R/V (36-50 psi)		471815	29	Pipe Plug Asy. ² (SAE # 6) (FKM)(Std.)	1	908212
	SS Spring - R/V (51-110 psi)		471807		Pipe Plug Asy. ² (SAE # 6) (PTFE)		908213
	SS Spring - R/V (111-150 psi)		471808	35	Key - Shaft	1	909177
SS Spring - R/V (151-200 psi) ¹	471869	42	Flange - 3" NPT (Std.) ⁴	2	651803		
9	Valve - R/V (Std.)	1	451807	42A	Gasket - NPT Flange (Comp.) (Std.) ⁴	2	381616
	Valve - R/V (Nickel Plated)		451808	42B	Capscrew - NPT Flange ⁵	8	920532
10	O-Ring - R/V Cover (FKM) (Std.)	1	711931		O-Ring - Head (FKM) (Std.)	2	702232
	O-Ring - R/V Cover (PTFE)		702080	72	O-Ring - Head (PTFE)		702233
12	Cylinder (Std.)	1	021805	72A	O-Ring (Small) - Jacket (FKM) ³	0 - 2	701991
	Cylinder w/Drain (Ductile Iron) ²		021815		O-Ring (Small) - Jacket (EPR) ³		702249
13	Rotor & Shaft (Std.)	1	261868	72B	O-Ring (Large) - Jacket (FKM) ³	0 - 2	702232
	Rotor & Shaft (Ext. Length)		261869		O-Ring (Large) - Jacket (EPR) ³		702254
14	Vane - Duravane (Std.)	6	091819	73	Gage Plug	2	908198
	Vane - Laminate		091809	77	Push Rods	3	121807
	Vane - EC Laminate		091829	88	O-Ring - R/V Cap (FKM) (Std.)	1	711908
	Vane - EC Cast Iron		091821		O-Ring - R/V Cap (PTFE)		702076

¹Optional High Pressure Relief Valve - parts must be used as a group (includes p/n's 411868, 920381, and either 471868 or 471869). ²SAE Plug standard with ductile iron cylinder (p/n 021815) and cast iron cylinder w/drain (p/n 021816). ³For hot oil circulation use FKM O-Rings; For steam circulation use EPR O-Rings. ⁴See backside for Flange Options. EC = Extra-Clearance SS = Stainless Steel

Keep this parts list with Installation, Operation and Maintenance Instructions.

KI Pumps & Systems, Inc.,
TEL (888) 547 8678

206 Enterprise Road, P.O. Box 180287,
FAX (262) 547 8678 info@kipumps.com

Delafield, WI 53018-1768
www.blackmerpumps.com

PACKING - STANDARD

Ref. No.	Part Name	Parts Per Pump	Part No.
17	Stud - Packing Follower	2	921868
18	Nut - Packing Follower Stud	2	922428
19	Packing Set	1	321868
58	Pack Washer	1	355168
75	Packing Follower	1	141868

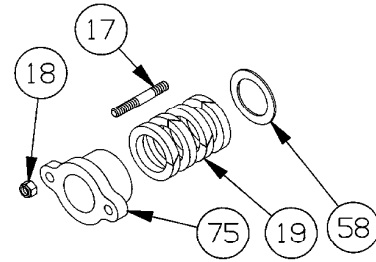

LIP SEAL - OPTIONAL

Ref. No.	Part Name	Parts Per Pump	Part No.
16	Capscrew - Follower	2	920359
75	Seal Follower	1	141868
152	Lip Seal Assembly (To 500°F)	1	702245
152D	Wave Spring	1	321601

NOTE: A Commercial Mechanical Seal (cartridge type) can be used in place of packing or lip seals. Consult mechanical seal manufacturer for more information.

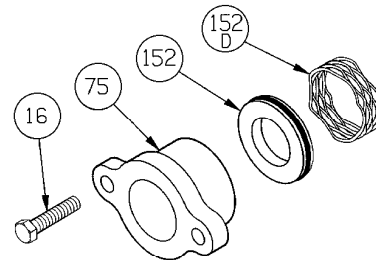

SHAFT SUPPORT BEARING – OPTIONAL*

Ref. No.	Part Name	Parts Per Pump	Part No.
See Below	Shaft Support Bearing Kit	See Below	891698
106	Bearing Housing	1	651414
106A	Locknut - Bearing Housing	4 - 6	922428
106B	Bearing & Collar Assembly	1	903136
106C	Cover - Bearing Housing	1	651409
106D	Stand Off - Bearing Support (for use with packing)	2	631603
	Stand Off - Bearing Support (for use with mechanical seal)	4	631602
106E	Stud - Bearing Support	4	921484
106F	Washer - Locknut	4	909665
106G	Bearing & Housing Assembly	—	631604

*Shaft Support Bearing is designed for use with Extended Length Rotor & Shaft - p/n 261869.

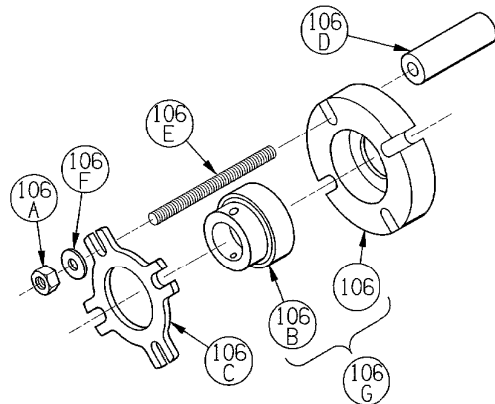

FLANGE OPTIONS

Ref. No.	Part Name	Parts Per Pump	Part No.
42	Flange - 3" Weld (shown on front)	0 - 2	655102
	Flange - DIN 80		651818
	Flange - ANSI 3"		651817
42B	Capscrew - Weld/DIN/ANSI Flg.	0 - 8	920510
42C	O-Ring - Flange (FKM)	0 - 2	701968
	O-Ring - Flange (PTFE)		702101

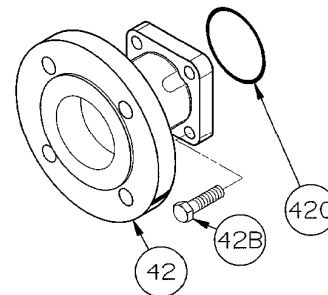

DIN / ANSI FLANGE