

# BLACKMER PARTS LIST

## PUMP MODELS: XRLW1.25A, XLW1.25A, XLW1.5A

XRLW1.25, XLW1.25, XLW1.5

(See Instructions 105-A00 for Installation, Operation and Maintenance)

Aug 2007: Discontinued Models, parts availability may be limited.

962303

Page 1 of 2

PARTS LIST

105-A01\_jan06

Section	100
Effective	Jan 2006
Replaces	May 2003

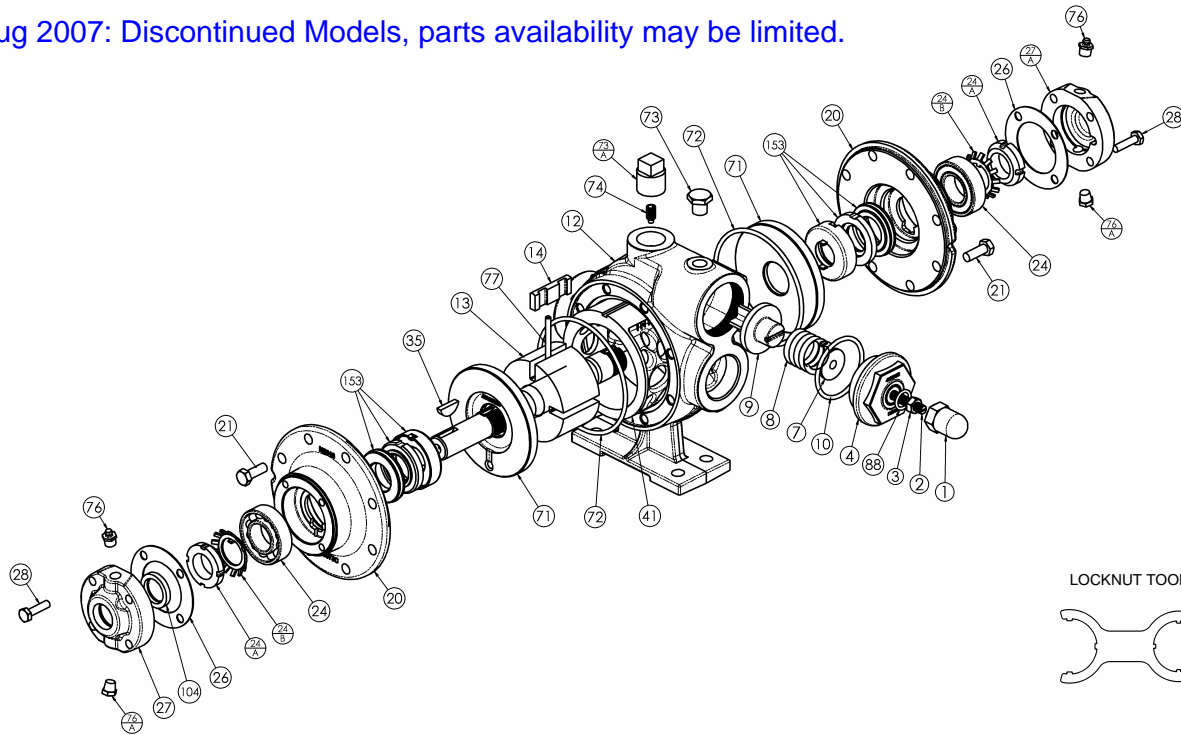

Ref. No.	Description	Parts per Pump	Part No.	Ref. No.	Description	Parts per Pump	Part No.
1	Cap – Relief Valve (R/V)	1	413200	26	Gasket – Bearing Cover	2	<sup>1</sup> 383075
2	Adjusting Screw – R/V	1	433909	27	Bearing Cover – Inboard	1	043070
3	Locknut – Adjusting Screw	1	922923	27A	Bearing Cover – Outboard	1	043071
4	Cover – R/V	1	413076	28	Capscrews – Bearing Cover	8	920080
7	Spring Guide – R/V	1	423955	35	Key – Shaft	1	<sup>1</sup> 909125
8	Spring – R/V (20 - 50 psi)	1	471415	41	Liner – XRLW 1.25	1	<sup>2</sup> 182326
	Spring – R/V (51 - 80 psi) (Std)		471420		Liner – XLW 1.25		<sup>2</sup> 182327
	Spring – R/V (81 - 150 psi)		471428		Liner – XLW 1.5		<sup>2</sup> 182626
	SS Spring – R/V (25 - 50 psi)		471417	71	Disc	2	<sup>2</sup> 063075
	SS Spring – R/V (51 – 75 psi)		471418	72	O-Ring – Head (FKM) (Std)	2	<sup>1</sup> 701991
	SS Spring – R/V (76 – 100 psi)		471427		O-Ring – Head (PTFE)		702066
9	Valve – R/V (Std.)	1	453079	73A**	Gage Plug (3/4")	1	908225
	Valve – R/V (Nickel Plated)		453073	74	Setscrew – Liner	1	922088
10	O-Ring – R/V Cover (FKM) (Std)	1	<sup>1</sup> 711924	76	Grease Fitting	2	317815
	O-Ring – R/V Cover (PTFE)		702084	76A	Grease Relief Fitting	2	701992
12	Casing (1.25)	1	013075	77	Push Rod – XRLW 1.25	2	<sup>1</sup> 123004
	Casing (1.5)		013376		Push Rod – XLW 1.25		<sup>1</sup> 123076
13	Rotor & Shaft Assembly (Includes Ref. Nos. 24A & 24B)	1	<sup>2</sup> 263076		Push Rod XLW 1.5		1
	Vane – Hardened Iron (Std)		<sup>1</sup> 092326	88	O-Ring – R/V Cap (FKM) (Std)	<sup>1</sup> 701908	
	Vane – Laminate		093089		O-Ring – R/V Cap (PTFE)	702074	
14	Vane – Extra Clearance Laminate	4	093091	104	Grease Seal	1	<sup>1</sup> 331927
						Tool - Locknut	
20	Head	2	033073	—	Kit – Maintenance - XRLW 1.25	—	898972
21	Capscrews – Head	16	920276	—	Kit – Maintenance - XLW 1.25	—	898984
24	Ball Bearing	2	<sup>1</sup> 903114	—	Kit – Maintenance - XLW 1.5	—	898973
24A	Locknut – Bearing	2	903534	—	Kit – Rebuild - XRLW 1.25	—	899072
24B	Lockwasher – Bearing	2	<sup>1</sup> 903533	—	Kit – Rebuild - XLW 1.25	—	899084
				—	Kit – Rebuild - XLW 1.5	—	899073

<sup>1</sup> Included in Maintenance and Rebuild Kits. <sup>2</sup> Included in Rebuild Kit

\*\* Ref. No. 73A: Earlier versions of these pumps may use a 1/4" plug (pn 908198) or 1/2" plug (pn 908215).

Keep this parts list with Installation, Operation and Maintenance Instructions.

**MECHANICAL SEAL**

Ref. No.	Part Name	Parts Per Pump	Part No.
153	Mechanical Seal Assembly (STD) Silicon Carbide Stationary Seat, Hardened Steel Rotating Seal Face, FKM O-Rings (LVSV)	2	1 <sup>1</sup> 332328
	Mechanical Seal Assembly Silicon Carbide Stationary Seat, Hardened Steel Rotating Seal Face, PTFE O-Rings (LAST)		332333
	Mechanical Seal Assembly Silicon Carbide Stationary Seat, Silicon Carbide Rotating Seal Face, FKM O-Rings (LVLV)		332335
	Mechanical Seal Assembly Silicon Carbide Stationary Seat, Silicon Carbide Rotating Seal Face, PTFE O-Rings (LALT)		332382
153A **	Stationary Seat (Silicon Carbide)	2	332303
153B **	Seal Face (Hardened Steel)	2	333048
	Seal Face (Silicon Carbide)		333024
153C **	Jacket Assembly	2	333057
153D	O-Ring – Stationary (FKM)	2	711908
	O-Ring – Stationary (PTFE)		702076
153E	O-Ring – Rotating (FKM)	2	701971
	O-Ring – Rotating (PTFE)		702201

<sup>1</sup> Included in Maintenance and Rebuild Kits

\*\* Ref. Nos. 153A, 153B, 153C are not available as separate parts.

