

BLACKMER LIQUEFIED GAS PUMPS FOR LP-GAS AND NH₃ SERVICE

INSTALLATION, OPERATION AND MAINTENANCE INSTRUCTIONS

MODELS: LGL2E, TLGLD2E, LGL3E, TLGLD3E

960417

INSTRUCTIONS NO. 585/E

Section	500
Effective	June 1995
Replaces	April 1989

GENERAL INFORMATION

SAFETY RULES

It is recommended that NFPA Pamphlet 58 be consulted for Safety Rules. Consult local and State regulations also.

WARNING

THIS PRODUCT MUST ONLY BE INSTALLED IN SYSTEMS WHICH HAVE BEEN DESIGNED BY THOSE QUALIFIED TO ENGINEER SUCH SYSTEMS. THE SYSTEM MUST BE IN ACCORDANCE WITH ALL APPLICABLE REGULATIONS AND SAFETY CODES AND WARN OF ANY HAZARDS UNIQUE TO THE PARTICULAR SYSTEM.

WARNING DANGER

DO NOT ATTEMPT TO OPEN THE PUMP UNTIL YOU HAVE BLEDED OFF THE PRESSURE. ON SYSTEMS WITH METERS, THE DIFFERENTIAL VALVE WILL KEEP LIQUID UNDER PRESSURE IN THE PUMP, METER AND PIPING EVEN WHEN THE HOSE IS EMPTIED.

PUMP DATA

	Size 2	Size 3
Nominal Capacity (GPM) (640 RPM—50 PSI) at Ambient Temperature of:		
80° F.	64	137
32° F.	51	107
Maximum Differential Pressure (PSI) (330 RPM to 640 RPM)	150	150
Maximum Pump Speed (RPM)	980	980
Maximum Differential Pressure (PSI) (at 980 RPM)	60	60
Pump Weight (LBS.)	85	160
Maximum Temperature (° F.)	240	240
Torque Required (FT-LB.) (at 100 PSI)	48	89
Model Designations:		
For Motor Drive	LGL2E	LGL3E
For Truck Mounting	TLGLD2E	TLGLD3E

These pumps are listed by Underwriters' Laboratories, Inc. for liquefied-petroleum gas and NH₃.

INSTALLATION AND OPERATION—MOTOR DRIVEN PUMPS

LOCATION

Locate the pump as near the source of supply as possible to reduce pipe friction. A good foundation reduces vibration and noise and improves the pump performance. On permanent installations, it is recommended that the pumping units be securely bolted to a concrete foundation.

When new pump foundations are to be cast in concrete, it is suggested that anchor bolts of the type shown in Fig. 1 be set into the concrete.

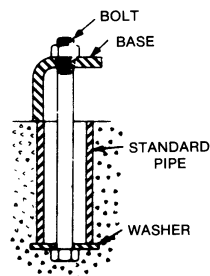

Fig. 1

RELIEF VALVE & BYPASS VALVE

The built-in spring loaded relief valve is to prevent damage to the pump or pumping system from excess pressure and

should not be used for recirculation. A separate bypass valve is required by Underwriters' Laboratories, Inc. piped from the pump discharge system back to the supply tank. The setting on the separate bypass valve should be at least 25 psi less than the relief valve setting. Do not pipe the bypass valve back to the intake line. The valve and piping should be of adequate size to accommodate the full flow from the pump when the discharge line is closed.

The Blackmer Model BV2 separate bypass valve can be mounted as shown in Fig. 2 for bulk plant installation.

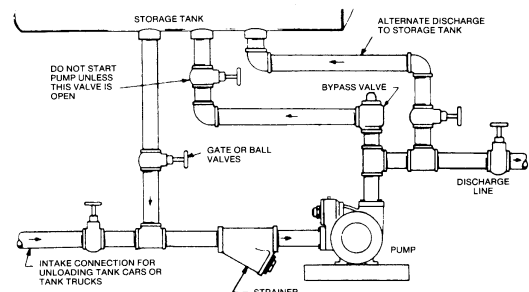

Fig. 2

STRAINER

The pump should be protected from foreign matter by the installation of a strainer in the intake line. A 40 mesh screen is recommended. It will prevent .010" and larger pieces of weld splatter, slag, etc. from entering the pump.

PIPING

Many pump systems deliver at a rate below the designated capacity of the pump because the system was improperly piped. Restrictions in the pipe line should be avoided, such as elbows, sharp bends, globe valves, certain restricted type plug valves and undersize strainers. Use pipe of adequate size and strength that has been thoroughly flushed before connecting to the pump. Less restrictive gate or ball valves should also be used. Flexible connectors used near the pump will compensate for expansion, contraction and will provide a more vibration free operation.

Unions and valves in the piping near the pump will facilitate maintenance. On the intake side, locate the nearest fitting at least six inches from the pump to permit the removal of the relief valve cover.

CAUTION

PUMP WITH WELDED CONNECTIONS

THE PUMP CONTAINS THREE NON-METALLIC "O" RING SEALS THAT WILL BE DAMAGED IF WELDING IS DONE WITH THESE "O" RINGS INSTALLED.

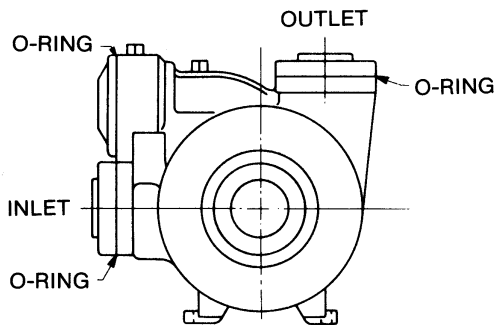

Fig. 3

Remove the "O" rings under the inlet flange, outlet flange and the relief valve cover then reinstall the inlet and outlet flanges.

Weld piping to inlet and outlet flanges and reinstall the three "O" rings.

When the unit is first started, rotation should be checked with the direction arrow on the pump. The discharge pressure should be compared to the supply pressure with a closed discharge. If the differential is over 100 psi, the separate bypass valve setting should be reduced.

Whenever possible, keep liquefied gas systems full of liquid, even when idle. This will keep the "O" rings from changing shape, shrinking or super cooling. Evaporation of liquefied gas leaves an abrasive powder on the surface which can cause wear to the pump, seals, meter, etc. If the system does not function properly, refer to the section on "Pump Troubles and Their Cures."

Use a vapor return line if possible. This will speed up delivery since a vapor line prevents back pressure from building up at the receiving tank, and a vacuum from forming in the supply tank. In laying out the system, read the section on "Pump Troubles" for suggested ways to eliminate difficulties before they develop.

ALIGNMENT

Where flexible couplings are used, the coupling cover should be removed and a straight edge laid across the two hubs of the coupling as shown in Fig. 4. The maximum offset should be less than .015".

With a feeler gage or piece of flat steel of proper thickness, check the space between the two coupling halves. Insert a gage at a point on the coupling, and at 90° increments about the coupling. The space should not vary more than .020". Misalignment is not desirable. If it does exist, it must not exceed the above limits.

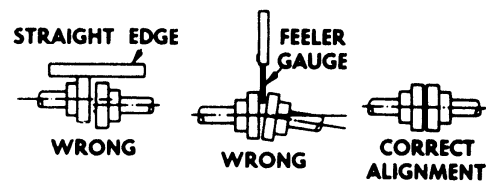

Fig. 4

The installation should be checked before being put into operation. Install a pressure gage in the gage hole nearest the discharge port provided on the pump casing before starting. Check all valves. The valves in the bypass return line must be open. After the pump is started, check the direction of the arrow on the pump head.

OPERATIONAL CHECK

The relief valve and separate bypass valve setting should be checked as described under Steps 8, 9 and 10 of Truck pump "Operation Check." The separate bypass valve on motor driven units is frequently set to protect the motor. If the pump is not delivering the expected flow rate, the separate bypass valve may be set too low and thus remain partially open. Remember that relief valves normally begin to bypass about 5 to 15 psi below their setting.

INSTALLATION AND OPERATION—TRUCK PUMPS

LOCATION

When locating the pump on the tank, safety should be the first consideration.

Locate the pump so that the suction line will be as short and straight as possible. Long suction lines lessen the capacity of a pump.

A large vapor return line should be used in all transport loading and unloading. Without such a line, the back pressure built up in the receiving tank, along with the vacuum in the supply tank, would noticeably reduce the flow rate and could cause constant bypassing. A 1½" or 2" (depending on length) vapor return hose and piping is recommended.

The outlet valve selected for the tank must give the desired flow rate without starving the pump.

PUMP ROTATION

An engine-wise rotation of the power take-off requires a right-hand pump for direct drive; anti-engine-wise a left-hand pump. When viewed from the shaft end, a right-hand pump turns clockwise, a left-hand pump counter-clockwise. Be sure your pump rotates in the same direction as the power take-off. The pump rotation is indicated by an arrow on the pump head. It should never be run in the reverse direction.

DRIVE

The pump may be driven by a power take-off from the transmission through universal joints. Additional pump shaft support is not necessary.

It is extremely important to install a proper drive line to avoid excessive wear, vibration and noise.

A few general rules to follow:

1. Use the least practical number of jackshafts (intermediate shafts).
2. Use an even number of universal joints.
3. The pump shaft and every other (alternate) jackshaft must be parallel to power take-off in both vertical and horizontal planes. The other shafts do not have to be parallel with anything.
4. Do not exceed 15° at any joint.
5. When unloading—align tractor with trailer.
6. An improperly designed drive line can result in a gallop or uneven turning of pump rotor which will impart a surging vibration to the liquid stream and piping system.

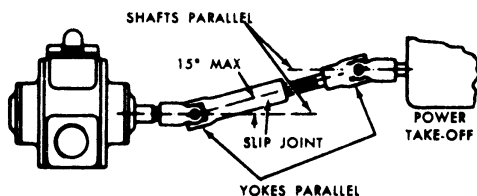

Fig. 5

PUMP SPEED

The higher the operating speed of the pump, the shorter the life of wearing parts. High pump speed may also cause continuous partial recirculation through the internal relief valve which will further shorten vane life. The operator should acquaint himself with these factors and, when making a delivery, set the engine to operate the pump at proper speed. The use of a tachometer is recommended. If the differential pressure on the pump is then over 100 psi the speed should be lowered, since part of the product will be recirculating through the bypass or relief valve.

OPERATIONAL CHECK

The following steps should be taken to check out a new system when it is placed in operation:

1. Install a pressure gage on the discharge side of the pump. (The difference between pump discharge pressure and the supply tank pressure is called the "Differential Pressure" in the following instructions.)
2. Connect the hose to the receiving tank.
3. Open the shut-off valve in the bypass return line.
4. If the tank outlet valve is:
 - (a) Lever Operated - Pull control knob all the way out. Manually check the lever under the truck to see that it is in a completely open position.
 - (b) Discharge Pressure Operated - Keep discharge line valve closed. When pump is started it will build up enough pressure to open the tank outlet valve. NOTE: This type of valve usually requires about 20 PSI differential pressure to open and about 15 PSI differential pressure to keep it open. If the piping is quite large it may be necessary to restrict the discharge line shut-off valve in order to maintain sufficient pressure to keep tank outlet valve open.
5. Start the pump.
6. Check pump rotation with the arrow on the pump.
7. Check pump speed (it should never exceed recommended maximum).
8. With discharge valve closed, check the differential pressure across the pump. It should not exceed the pressure setting of the separate bypass valve.
9. With discharge valve still closed, momentarily close the manual shut-off valve in the bypass return line to check the pump relief valve. The differential pressure should be between 150 psi and 170 psi.
10. The separate bypass valve must always be set lower than the relief valve. If the valves work properly, the pump should now be ready to operate. Note that the normal operating pressure should be at least 5-15 psi less than the separate bypass setting. Pump speeds which result in higher pressures (nearing the valve setting) mean that liquid is being recirculated uselessly. Slow the engine down, thereby eliminating needless wear on the equipment.

Whenever possible, keep liquefied gas systems full of liquid, even when idle. This will keep the "O" rings from changing shape, shrinking or super-cooling.

MAINTENANCE

**MAINTENANCE AND TROUBLE SHOOTING
MUST BE DONE BY AN INDIVIDUAL EXPERIENCED
WITH PUMP MAINTENANCE AND THE
TYPE OF SYSTEM INVOLVED.**

LUBRICATION

Pump bearings should be lubricated every three months.

Recommended Grease: *Amoco® - Amolith All Weather Grease*, or equivalent (must be paraffinic base).

Apply grease with a hand pressure gun until it appears at the grease relief fitting.

It is normal for some grease to escape from the tell-tale holes under the bearing covers for a short period after lubrication. If this condition persists, the head must be removed and the mechanical seal replaced.

On motor-driven units using a gear reducer, the oil in the gear case should be maintained to the oil level plug hole, and changed every 6 months.

DISASSEMBLY

Before work is started on a pump it must be drained and the gas pressure relieved.

The size 2 pumps have dirt shields on the shafts; the double-end shaft models have one on each shaft. These shields will slide off the shaft with the bearing cover after removing the bearing cover capscrews.

Bearings are located by collars and serve as thrust bearings to position the rotor in the casing. It is necessary to remove the locknut and lockwasher, from each end of the rotor shaft, before each head can be removed. Remove the bearing cover, wipe off the excess grease, and locate the lockwasher tang that is staked into one of the locknut slots. Using a small blade screwdriver, pry up the staked lockwasher tang and remove the locknut. Remove the head capscrews and use two (2) large screwdrivers to pry the head loose from the casing around the head O.D. Slide the head assembly off the rotor shaft and use care not to drop the bearing.

The stationary seat, of the seal and its "O" ring, will come off the shaft as part of the head assembly. To remove the stationary seat, remove the bearing and use a screwdriver to push the stationary seat out of its cavity. The seal face and seal jacket may require a light pry to be slid off the shaft. Wipe the shaft and inspect for pits under the seal face "O" ring. If the seal has been leaking, it is advisable to replace the entire seal, including the stationary seat and its "O" ring. It is important to keep all parts of the seal clean.

With a pick or small screwdriver, slide out the three (3) uppermost vanes noting which side the slots are on. Inspect the edges of these vanes, that contact the liner, for gouges, ridges

and tears. Replace these vanes and rotate the rotor shaft 180 degrees. Remove and inspect the top three (3) vanes. If vanes are damaged, it is advisable to remove the rotor and inspect the liner.

Remove the remaining head and hold the bottom vanes in the vane slot to prevent the push rods from jamming the rotor while it is being removed. Using a hard wood or brass drift and hammer, tap the liner around its outer edge to drive it out of the casing.

ASSEMBLY

Before assembling the pump, clean each part thoroughly. Wash out the bearing and seal cavities, and the recessed areas of the casing. Remove any burrs from the liner with a file.

On 2-inch pump models, apply grease to the liner key groove inside the pump casing to hold the key in place for liner insertion. Install the key in the groove before starting liner into casing. On 3-inch models, install the key in the keyway on the top of the liner. Align the liner keyway with the casing keyway and start the liner into the pump casing with the slots in the liner towards the casing intake port and with the hole pattern towards the discharge port. Use a rubber mallet to uniformly tap around the edge of the liner to fully install in the casing. If the liner is installed backwards it will restrict the port openings, causing noise and loss of capacity.

TLGL pump models are equipped with a double-ended rotor and shaft which allows the pump to be driven from either end.

LGL pump models are equipped with a single-ended rotor and shaft which can be assembled for either left-hand (LH) or right-hand (RH) rotation. To determine rotation:

If the intake port is on the right, with the drive end of the shaft pointing towards the observer, the pump is right-hand, clockwise rotation.

If the intake port is on the left, with the drive end of the shaft pointing towards the observer, the pump is left-hand, counter-clockwise rotation.

Install three (3) of the vanes in the bottom slots of the rotor with the rounded edges out and the relief grooves facing in the direction of rotation (see Figure 6). Hold the vanes in place and install the three push rods. With the hand cupped under the rotor, slide the rotor and shaft into the liner. Install the remaining three vanes into the top slots of the rotor with the rounded edges out and the relief grooves facing in the direction of rotation. Put a light coating of oil on both ends of the shaft between the threads and the rotor.

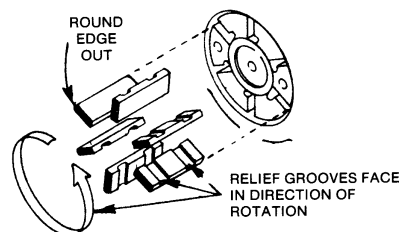

Fig. 6

Install a disc, against the liner, with the seal cavity outward and the disc hole radially positioned as shown in Fig. 7. Slide the seal jacket assembly over the shaft, with the drive tangs towards the rotor. Rotate the seal jacket assembly to get its tangs through the disc and engaged in the two (2) drive holes in the rotor. Insert the rotating "O" ring into the seal face and slide this subassembly, with polished mating face outward, over the shaft to the seal jacket assembly. Rotate the seal face to align the drive notches. Wipe any dirt, oil or grease off the mating surface of the seal face with a clean tissue (not a shop cloth).

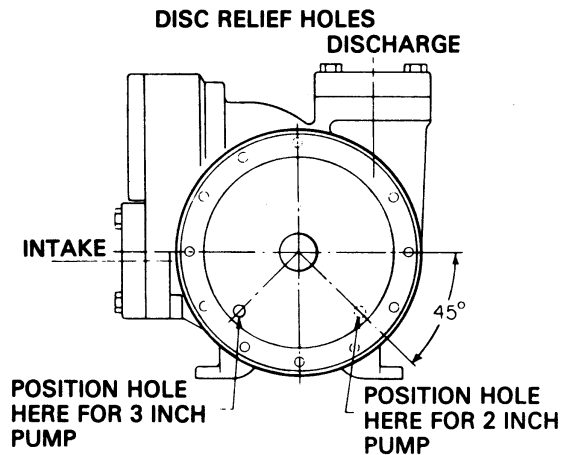

Fig. 7

With the head resting on its bearing boss, put a light coating of oil on the stationary seat cavity. Install the "O" ring in the groove around O.D. of the stationary seat. A pin, projecting from the back surface of the stationary seat, must be radially positioned to align with a notch at the bottom of the stationary seat cavity. Push the stationary seat into the cavity and make certain it is down. Wipe the mating face, of the stationary seat with tissue to remove any dirt, oil or grease.

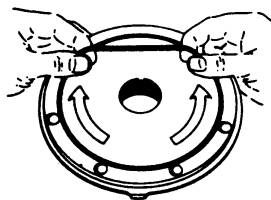

Fig. 8

The head "O" ring should be replaced if it is swollen, nicked, or cut. It is normally smaller in diameter than the "O" ring groove. To install, lay the ring flat on the head and start on one side of the groove. Slide thumbs over the "O" ring in opposite directions, stretching ahead with the fingers as shown in Fig. 8. If the "O" ring is rolled into the groove, it will roll right out.

Install the head assembly over the rotor shaft being careful to avoid any contact between the end of the rotor shaft and the mating face of the stationary seat. Rotate the head so that the drain hole, at the rear of the bearing cavity, is down when the pump is mounted for operation. Hold the head against the casing and install four (4) head capscrews, 90° apart. Snug up the four (4) capscrews but do not tighten. Install the bearing with the seal side in and the balls visible. Carefully tap the bearing outer race to seat the bearing in its cavity. Use the same procedure to install the second disc, seal assembly, head and bearing.

Install lockwashers and locknuts on both ends of the rotor shaft and tighten both locknuts very tight. Tighten the four (4) head capscrews holding each head, and loosen both bearing locknuts. Rotate the rotor shaft, by hand, to determine if any binding or tight spots exist. Any of these conditions may be corrected by loosening the four (4) capscrews, on one head, approximately one-half turn and tapping that head up or down, with a lead hammer. When the correct position is found, tighten the four (4) loosened capscrews and recheck for binding. Install and tighten all of the remaining head capscrews.

Tighten one bearing locknut until increased drag is noted, while turning the rotor shaft. Then tighten the other locknut until the increased drag disappears. Locate the closest lockwasher tang to a locknut slot, align these two and stake the tang into the slot. Repeat this operation with the second locknut then install gaskets and bearing covers on both ends. The bearing covers should be installed with the grease fittings up on stationary installations and down on mobile installations.

TO REVERSE PUMP ROTATION

Pump rotation, of LGL pumps, may be reversed by changing the side that the drive end of the shaft projects from the pump. Bearing covers, locknuts and one head must be removed to reverse the shaft. Previously covered "Disassembly and Assembly" Instructions apply.

PUMP TROUBLES AND THEIR CURES

VANE WEAR

Vane wear and push rod penetration are usually caused by excessive vapors entering the pump (called cavitation) or by abrasives in the liquid. Cavitation causes the vanes to "bounce" violently and sometimes is accompanied by noise and vibration.

Intake piping should be at least 2" on the LGL2 and TLGLD2 and at least 3" on the LGL3 and TLGLD3. For longer runs the next size larger piping should be used. Cavitation can be caused by circulation of liquid through the built-in relief valve on the pump, or through the separate bypass valve improperly piped back into the intake pipe. This can also happen if the pump valve operates at a lower differential pressure than the separate bypass valve, even though the separate bypass valve discharges into the supply tank. Check the setting of the separate bypass valve. Cavitation is also caused by restricted intake piping, small or defective excess flow valve, plugged or too fine a strainer basket, and the use of globe valves instead of ball-type or gate-type valves.

All the above conditions are aggravated if the pump is running too fast and is trying to deliver liquid faster than the piping can handle it.

One or more vanes installed backwards will cause noise and loss of capacity.

DAMAGED PUMP PARTS

Worn or scored discs can be caused by improper adjustment of the locknuts.

Corrosion of pump parts can be caused by calcium chloride brine carried over from dehydrators. Corrosion may damage internal parts and weaken the entire system. Corrective action should be taken immediately to eliminate the cause of corrosion.

LEAKAGE

Mechanical seals can be damaged and begin leaking from using the wrong grease, greasing with a high pressure gun, dirt or abrasive particles entering between the seal faces, cut or otherwise damaged "O" rings.

Leakage may appear at the drain holes under the bearing housing on the pump head. If leakage becomes excessive the entire mechanical seal assembly should be replaced. Leakage between the heads and pump casing is caused by a cut, nicked or damaged head "O" ring and the "O" ring must be replaced.

ROTOR AND DISC WEAR

Worn universal joints or a slip-joint that does not slip under load are the two most common causes for excessive end thrust on the pump shaft. This will cause the rotor to wear into the pump discs.

The most effective slip-joint is a well lubricated close fitting splined slip-joint. These commercially manufactured slip-joints will move axially under a high torque (rotating load). Worn, dry or dirty slip-joints especially the square "home-made" type will slip axially when the pump running, but when under load with the pump running the slip-joint becomes rigid. This can result in severe end thrust and wear to the pump.

NOISE AND VIBRATION

The most frequent cause is recirculation through the pump relief valve, caused by malfunction of the separate bypass or high bypass setting.

Another cause is excessive cavitation from a restricted intake, dirty strainer, small excess flow valve, too long or too small intake pipe.

Other possible causes—one or more vanes installed backwards, universal joints out of phase.

LOSS OF CAPACITY

The most probable causes are: restricted valve in pipe line; restricted excess-flow valve at tank outlet; cavitation; pump rotating backward; worn vane, disc, liner or rotor; pump located too far from storage tank (see paragraph on Location under "Motor Driven Pumps").

Cavitation and vapor binding may be caused by circulation of liquid through the relief valve. This will happen if the separate relief valve is set too high, is too small, or if the piping on the valve is too small. It can also be caused by overheating the pump or piping from hot sunshine or being located near a hot exhaust pipe.

If the excess-flow valve closes, it is an indication of trying to deliver too fast. The pump speed should be reduced.

Capacity without a vapor return line will be less than when a vapor return line is used.

blackmer
A  COMPANY